

## Original version of the operating instructions



**HOISI** | 凯狮精密  
PRECISION | 180 7312 9830



For	Components							
Spieth clamping set (precision clamping sets)	DSK 14.26	DSL 14.26	DSK 30.42	DSL 30.42	DSK 50.75	DSL 50.75	DSK 140.170	DSL 140.170
	DSK 15.28	DSL 15.28	DSK 30.47	DSL 30.47	DSK 50.80	DSL 50.80	DSK 150.180	DSL 150.180
	DSK 16.28	DSL 16.28	DSK 30.50	DSL 30.50	DSK 55.80	DSL 55.80	DSK 160.190	DSL 160.190
	DSK 16.32	DSL 16.32	DSK 30.55	DSL 30.55	DSK 55.85	DSL 55.85	DSK 170.200	DSL 170.200
	DSK 18.30	DSL 18.30	DSK 32.48	DSL 32.48	DSK 60.85	DSL 60.85	DSK 180.210	DSL 180.210
	DSK 18.35	DSL 18.35	DSK 32.52	DSL 32.52	DSK 60.90	DSL 60.90	DSK 190.230	DSL 190.230
	DSK 20.32	DSL 20.32	DSK 32.56	DSL 32.56	DSK 65.90	DSL 65.90	DSK 200.240	DSL 200.240
	DSK 20.37	DSL 20.37	DSK 35.52	DSL 35.52	DSK 65.95	DSL 65.95	DSK 210.250	DSL 210.250
Series	DSK 20.40	DSL 20.40	DSK 35.55	DSL 35.55	DSK 70.100	DSL 70.100	DSK 220.260	DSL 220.260
	DSK 22.35	DSL 22.35	DSK 35.60	DSL 35.60	DSK 75.105	DSL 75.105	DSK 230.270	DSL 230.270
DSK/DSL	DSK 22.38	DSL 22.38	DSK 40.56	DSL 40.56	DSK 80.110	DSL 80.110	DSK 240.280	DSL 240.280
	DSK 22.42	DSL 22.42	DSK 40.62	DSL 40.62	DSK 85.120	DSL 85.120	DSK 250.300	DSL 250.300
	DSK 25.37	DSL 25.37	DSK 40.65	DSL 40.65	DSK 90.120	DSL 90.120	DSK 260.310	DSL 260.310
	DSK 25.42	DSL 25.42	DSK 40.70	DSL 40.70	DSK 95.125	DSL 95.125	DSK 270.320	DSL 270.320
	DSK 25.45	DSL 25.45	DSK 45.68	DSL 45.68	DSK 100.130	DSL 100.130	DSK 280.330	DSL 280.330
	DSK 28.40	DSL 28.40	DSK 45.70	DSL 45.70	DSK 110.140	DSL 110.140	DSK 290.340	DSL 290.340
	DSK 28.45	DSL 28.45	DSK 45.75	DSL 45.75	DSK 120.150	DSL 120.150	DSK 300.350	DSL 300.350
	DSK 28.48	DSL 28.48	DSK 50.72	DSL 50.72	DSK 130.160	DSL 130.160		

The Operating Instructions are also available for download at [www.spieth-me.de](http://www.spieth-me.de). In case of any questions, please contact Spieth-Maschinenelemente GmbH & Co. KG directly.

### Legal:

SPIETH-MASCHINENELEMENTE GmbH & Co. KG, Alleenstraße 41, D - 73730 Esslingen

Phone +49 711 930730 0 - Fax +49 711 930730 7

E-Mail: [info@spieth-me.de](mailto:info@spieth-me.de) - Web: [www.spieth-me.de](http://www.spieth-me.de)

KG: Esslingen HQ, Stuttgart county court, company register sect. A 210689

PhG: Spieth-Beteiligungs-GmbH, Esslingen HQ, Stuttgart county court, company register sect. A 210636

Managing director: Dipl.-Ing. Alexander Hund

©Spieth Proprietary notice ISO 16016	Previous document: ba-dskl-en1604	See
	Successive document: N/A	<a href="http://www.spieth-me.de/english/service-download/catalogue-instructions/">www.spieth-me.de/english/service-download/catalogue-instructions/</a>
	Created: 13 Apr 2018/Fd	For any questions, requests or suggestions, please contact
	Checked: 13 Apr 2018/Ax	<a href="mailto:info@spieth-me.de">info@spieth-me.de</a>

### About the operating instructions for Spieth clamping sets

These operating instructions enable safe and efficient handling of Spieth clamping sets. Prior to performing any tasks, ensure that your staff have carefully read and fully understood these operating instructions.

### Notices

The basic requirement for working safely is compliance with all specified safety notices. They can be identified by the following symbols:

**Caution!**

In addition to the notices in these instructions, local accident prevention guidelines and national health and safety regulations also apply.

### Table of contents

1	Information about Spieth Clamping Sets .....	3
1.1	General information .....	3
1.2	Safety notices .....	3
1.3	Information on connecting components .....	4
2	Description of Spieth Clamping Sets .....	4
2.1	Structure .....	4
2.2	Mode of action .....	4
2.3	Intended use .....	5
3	Delivery Contents and Storage of Spieth Clamping Sets .....	6
3.1	Delivery contents of the Spieth Clamping Sets .....	6
3.2	Storage and shelf life of the Spieth Clamping Sets .....	6
4	Assembling Spieth Clamping Sets .....	6
4.1	Preparing for assembly .....	6
4.2	Ambience .....	7
4.3	Assembly process .....	7
5	Using Spieth Clamping Sets .....	8
6	Disassembling Spieth Clamping Sets .....	8
7	Disposing of Spieth Clamping Sets .....	9

## 1 Information about Spieth Clamping Sets

### 1.1 General information

Please read these operating instructions carefully, paying special attention to our safety notices. These operating instructions are part of your product and must be kept accessible to the staff in the immediate vicinity of the product at all times. The operating instructions are also available for download at [www.spieth-me.de](http://www.spieth-me.de).

In case of any questions, please contact Spieth-Maschinenelemente GmbH & Co. KG directly.

**Caution!**

It is mandatory to comply with the recommendations and notices in these operating instructions.

Inform the end user about the contents of these operating instructions.

Spieth-Maschinenelemente GmbH & Co. KG assumes no liability for damage caused by (i) misinterpreting or nonobserving the operating instructions; (ii) improper use; (iii) incorrect installation or unauthorised structural changes; or (iv) incorrectly circulating or failure to circulate the contents of these operating instructions to third parties.

These operating instructions apply on the assumption that the chosen product is valid for the use case. Please see the related design guide (available at [www.spieth-me.de](http://www.spieth-me.de)) for specifications, characteristics, and information on choosing Spieth clamping sets.

### 1.2 Safety notices

Spieth clamping sets are intended for use with friction-locked shaft-hub connections. Please follow all relevant safety notices.

**Caution!**

Any work carried out with or on the clamping set needs to follow the "safety first" guideline!

During operation, keep your hands away from the working area of the the clamping set!

Prior to any assembly work, switch off all machine drives!

Secure the machine against accidental power-up!

Prior to commissioning the machine, install all safety devices!

Only expert personnel are allowed to perform assembly work on Spieth clamping sets. Using Spieth clamping sets is only admissible according to specifications. Spieth-Maschinenelemente GmbH & Co. KG assumes no liability for violations of the operating instructions or safety notices. This also applies to incorrectly interpreting or circulating these notices and to incorrect assembly or maintenance.

The clamping sleeves described here are state of the art at the time these assembly instructions are printed. Subject to changes based on evolved technologies.

For international deliveries, follow the safety regulations applicable in the target country.

©Spieth Proprietary notice ISO 16016	Previous document: ba-dskl-en1604	See
	Successive document: N/A	<a href="http://www.spieth-me.de/english/service-download/catalogue-instructions/">www.spieth-me.de/english/service-download/catalogue-instructions/</a>
	Created: 13 Apr 2018/Fd	For any questions, requests or suggestions, please contact
	Checked: 13 Apr 2018/Ax	<a href="mailto:info@spieth-me.de">info@spieth-me.de</a>

### 1.3 Information on connecting components

In general, produce shafts according to manufacturing tolerance h5 (no more than h6 is admissible). For hub boreholes, a manufacturing tolerance of H7 (or H6 for high radial run-out requirements) applies.

## 2 Description of Spieth Clamping Sets

### 2.1 Structure

Spieth clamping sleeve  
 Spieth clamping screws

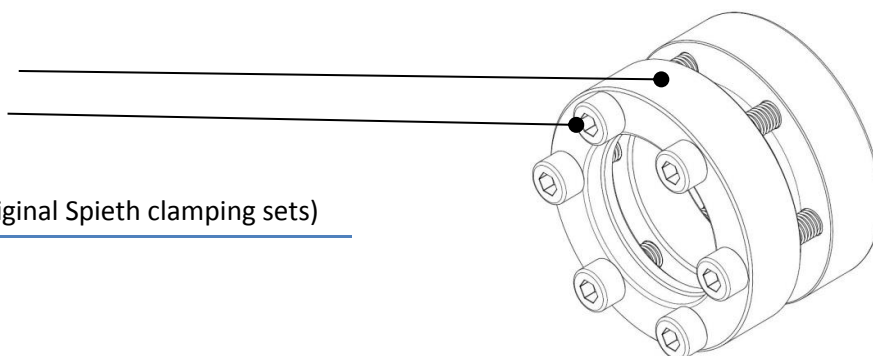

#### Identifying features (for original Spieth clamping sets)

Spieth logo

Name

Batch number

Pretensioning torque  $M_V$  of the clamping screws

Fig. 1: Schematic representation similar to Spieth DSK/DSL series clamping sets

Spieth DSK/DSL series clamping sets have been designed for use on shafts with h5-tolerance zone. The assembly consists of a clamping sleeve and clamping screws for integrated clamping initiation. In contrast to tapered clamping sets, the one-piece cylindrical clamping sleeve has no tolerance-heavy joints and can therefore achieve a higher degree of precision.

### 2.2 Mode of action

Spieth clamping sets are precision clamping sets. Due to their design, they provide a maximum of precision, combined with utmost resilience.

Spieth DSK/DSL series clamping sets have been designed as all-purpose precision clamping sets. This makes them an ideal solution for applications with a high level of replacements and adjustments.

Despite their compact design they can ensure continuous load transmission and rigid connections together with precise, centering and optimum concentricity for applications with high torques and axial forces.



Fig. 2: Illustration similar to Spieth DSK/DSL clamping sets

Spieth DSK/DSL series clamping sets are classified as friction-locked shaft-hub connections. Using clamping screws to initiate axial clamping achieves a uniform lateral contraction thanks to the base body's special geometry. The diaphragms are raised, widening the outer diameter and reducing the inner diameter, to create the required

©Spieth Proprietary notice ISO 16016	Previous document: ba-dskl-en1604	See
	Successive document: N/A	<a href="http://www.spieth-me.de/english/service-download/catalogue-instructions/">www.spieth-me.de/english/service-download/catalogue-instructions/</a>
	Created: 13 Apr 2018/Fd	For any questions, requests or suggestions, please contact
	Checked: 13 Apr 2018/Ax	<a href="mailto:info@spieth-me.de">info@spieth-me.de</a>

contact with shaft and hub for transmitting torques and axial forces. Thanks to this diaphragm principle, the connection is easy to assemble and quick to undo without the need for applying additional force.

### 2.3 Intended use

Spieth clamping sets are recognised state of the art. They are intended for use as reliable high-quality shaft-hub connections. Any other usage is regarded as improper use.

Spieth-Maschinenelemente GmbH & Co. KG reserves the right to technical changes. In case of any questions or technical issues, please contact Spieth-Maschinenelemente GmbH & Co. KG.

**Caution!**  
Only expert personnel are allowed to choose, assemble, operate, and service Spieth clamping sets.

Use Spieth clamping sets only according to product-specific specifications. To ensure proper functioning of the Spieth clamping sets, it is mandatory to comply with the specifications of the connecting components. Detailed information on the above items can be found in the Design Guide. Operating conditions, e.g. speeds and temperatures at which the Spieth clamping sets are used must not exceed common standards.

**Caution!**  
The user assumes responsibility for proper shaft and hub design, for determining the operating loads and meeting permissible operating conditions. In case of any questions or technical issues, please contact Spieth-Maschinenelemente GmbH & Co. KG.

In case operating conditions change, it is mandatory to check if the clamping set is still suitable for further use. Spieth clamping sets need to be handled with care, assembled correctly, and used as intended to achieve their full functional potential. Prior to working with our clamping sets, please read these operating instructions carefully. In particular, please follow all relevant safety notices.

**Caution!**  
It is mandatory to comply with the instructions for use and the general safety notices!  
Handle clamping sets with care before and during assembly; assemble them according to these operating instructions and/or the according assembly instructions. Use only stipulated tools for assembling clamping sets.  
Incorrect handling or the use of inadequate aids can severely limit, damage, or destroy the machine element and/or the machine in its functionality.

Spieth clamping sets are not meant to be repaired; if repairs are necessary in exceptional cases, only the manufacturer is allowed to perform them.

©Spieth Proprietary notice ISO 16016	Previous document: ba-dskl-en1604	See
	Successive document: N/A	<a href="http://www.spieth-me.de/english/service-download/catalogue-instructions/">www.spieth-me.de/english/service-download/catalogue-instructions/</a>
	Created: 13 Apr 2018/Fd	For any questions, requests or suggestions, please contact
	Checked: 13 Apr 2018/Ax	<a href="mailto:info@spieth-me.de">info@spieth-me.de</a>

### 3 Delivery Contents and Storage of Spieth Clamping Sets

#### 3.1 Delivery contents of the Spieth Clamping Sets

Spieth DSK/DSL series clamping sets have been treated and packaged with a preservative. Opening the cover or removing the component can reduce the duration of the corrosion protection even if the component is later repackaged.

In case of complaints, please contact Spieth-Maschinenelemente GmbH & Co. KG with your multi-digit picking number at hand. In case you have to return the component, please package it with care, affix a shipping label, and send it to Spieth-Maschinenelemente GmbH & Co. KG.

If functional surfaces exhibit thin blank lines, then they have been created during our quality assurance process when measuring the components. They do not impact the functionality of the components and constitute no defects.

The clamping screws of Spieth clamping sets have been designed as ready for assembly.

#### 3.2 Storage and shelf life of the Spieth Clamping Sets

In our experience, the corrosion protection is effective for up to two years, provided you bear the following in mind during the storage period:

- The storeroom is clean and enclosed
- Packaged parts are protected from mechanical influences
- The storeroom is dry (rel. humidity < 65%)
- The temperature range is 0°C to 40°C
- No corrosive media such as gases, vapors, or liquids can act

### 4 Assembling Spieth Clamping Sets

#### 4.1 Preparing for assembly

Remove Spieth clamping sets from their packaging right before assembly. As hand perspiration can cause corrosion, ensure to keep your hands dry and clean and/or to always wear protective gloves for assembly.

Please note:  
For environmental reasons, please comply with applicable statutory regulations and guidelines when disposing of packaging materials.

In case of damage to packaging components, check the clamping sets for damage and remove any contamination. The preservative used is compatible with all conventional machine oils. If in doubt, check the preservative's compatibility.

For an optimum mode of action of Spieth clamping sets, remove the thin wax-like film of preservative from the contact surfaces using a lint-free cloth. Directly afterwards, use machine oil without friction-reducing additives to lightly oil the component and protect it from corrosion.

©Spieth Proprietary notice ISO 16016	Previous document: ba-dskl-en1604	See
	Successive document: N/A	<a href="http://www.spieth-me.de/english/service-download/catalogue-instructions/">www.spieth-me.de/english/service-download/catalogue-instructions/</a>
	Created: 13 Apr 2018/Fd	For any questions, requests or suggestions, please contact
	Checked: 13 Apr 2018/Ax	<a href="mailto:info@spieth-me.de">info@spieth-me.de</a>

## 4.2 Ambience

During assembly, ensure that...

- the assembly location is free from dust and clean,
- the components have no contact with corrosive media,
- foreign bodies such as sand, sawdust, fluff, etc. are kept away from the component,
- metal filings (in particular from machining tools such as files, etc.) are kept away from the component.

**Caution!**

Contamination can significantly impact the functionality and service life of Spieth clamping sets.

For best results, use a suitable, enclosed space for assembly and proceed swiftly. If this is not possible, make sure to protect the components from ambient contamination and from damage.

## 4.3 Assembly process

Essentially, assembly is a 4-step process:

- 1. Cleaning and oiling
- 2. Joining
- 3. Removing clearance
- 4. Clamping initiation

For an optimum mode of action of Spieth clamping sets, perform all four assembly steps in the specified order.

**Caution!**

To initiate clamping, use only original Spieth clamping screws. Only actuate the clamping screws if borehole and outer surface of the clamping set are fully covered by the connecting components.

Otherwise, damage such as plastic deformation may occur on the clamping sleeve and render it unusable.

In such a case, Spieth-Maschinenelemente GmbH und Co. KG assumes no liability or warranty.

Use only the following assembly process for assembling Spieth DSK/DSL series clamping sets:

### 4.3.1 Cleaning and oiling:

For optimum application, carefully clean clamping set, shaft and hub borehole and lightly dab them with conventional fluid machine oil without friction-reducing additives.

### 4.3.2 Joining:

Join clamping set and connecting components without applying too much force to ensure that the clamping set contact surfaces are fully covered.

### 4.3.3 Removing clearance:

Tension the clamping screws crosswise and stepwise until you have fully removed the clearance with hub and shaft. Uniform removal of clearance is particularly important for good radial run-out.

©Spieth Proprietary notice ISO 16016	Previous document: ba-dskl-en1604	See
	Successive document: N/A	<a href="http://www.spieth-me.de/english/service-download/catalogue-instructions/">www.spieth-me.de/english/service-download/catalogue-instructions/</a>
	Created: 13 Apr 2018/Fd	For any questions, requests or suggestions, please contact
	Checked: 13 Apr 2018/Ax	<a href="mailto:info@spieth-me.de">info@spieth-me.de</a>

#### 4.3.4 Clamping initiation:

Continue to tighten clamping screws evenly and repeatedly, crosswise and stepwise until applying the full torque (see design guide/see note). Only tension Spieth clamping sets if using original Spieth clamping screws and once borehole and outer surface of the clamping sleeves are fully covered by shaft and hub. Then check pretensioning torque  $M_V$  all across.

In case of maximum demands on hub-shaft concentricity you can individually adjust the clamping screws to achieve the desired result.

**Please note:**

During the clamping process, the clamping sleeve shrinks by a few tenths of a mm, which, despite a symmetrically acting operating force from the clamping screws, can result in a minor axial displacement of the clamped part in undefined direction.

Afterwards, check the tightening torque of the clamping screws all across.

Following specified assembly, Spieth clamping sets are ready for use immediately.

Please see the relevant assembly instructions, available at [www.spieth-me.de](http://www.spieth-me.de), for more information on assembly.

## 5 Using Spieth Clamping Sets

Spieth clamping sets are maintenance-free. During general maintenance work, we nevertheless recommend visually inspecting the clamping set and checking pretensioning torque  $T_P$  of the clamping screws. If used as intended, Spieth clamping sets and their high level of radial run-out accuracy result in a friction-locked shaft-hub-connection for high torque values and axial forces.

Follow general safety notices when using Spieth clamping sets.

**Caution!**

Never touch actively rotating components. Take protective measures against accidental contact.

If you notice irregularities with the Spieth clamping sets during operation, immediately switch off the machine's drive.

## 6 Disassembling Spieth Clamping Sets

If handled correctly, Spieth clamping sets can be reused several times. Undo the clamping screws to return the cylindrical clamping set into its original shape.

In case you used a Spieth clamping set to friction-lock a shaft and a hub, due to the adjustments made you can only reconnect these two components after they have been disassembled.

**Caution!**

Undo all the clamping screws stepwise and crosswise to avoid overstraining the screws. Otherwise, the screws may fracture or the clamping set or adjoining components may be damaged.

©Spieth Proprietary notice ISO 16016	Previous document: ba-dskl-en1604	See
	Successive document: N/A	<a href="http://www.spieth-me.de/english/service-download/catalogue-instructions/">www.spieth-me.de/english/service-download/catalogue-instructions/</a>
	Created: 13 Apr 2018/Fd	For any questions, requests or suggestions, please contact
	Checked: 13 Apr 2018/Ax	<a href="mailto:info@spieth-me.de">info@spieth-me.de</a>



To disassemble, proceed in reverse assembly order.

- 1. Remove the clamping force by undoing the clamping screws stepwise and crosswise.
- 2. After undoing the clamping screws, all parts of the connection regain their free movement.

Please note:

Following several assembly processes, the friction conditions on the clamping screws between upper and contact surfaces may change unfavourably. Tightening may result in stick-slip effects, resulting in erratic movements (cracking) of the clamping screws. In that case, first relubricate the screwhead support using normal machine oil without additives. If the stick-slip effects persist, replace the clamping screws by new original Spieth clamping screws.

Please note:

Following complete disassembly, slightly (manually) tighten the loosened clamping screws until they are flush. In any case, avoid tightening the clamping screws without fully covered contact surfaces of the clamping set.

To enable later reuse, clean, preserve, and store Spieth clamping sets correctly. Prior to reuse, proceed as detailed in Section 4.1, "Preparing for assembly" ff.

If non-original Spieth spare parts are used, Spieth-Maschinenelemente GmbH & Co. KG assumes no liability or warranty.

## 7 Disposing of Spieth Clamping Sets

You can easily reorder Spieth clamping sets by entering the component designation imprinted on the clamping set and the batch number.

Clamping sleeve and clamping screws of a Spieth clamping set are made of steel. At the end of their operating life, clean metal parts and dispose of them as scrap metal.

Please note:

For environmental reasons, please comply with applicable statutory regulations and guidelines when disposing of these products.

©Spieth Proprietary notice ISO 16016	Previous document: ba-dskl-en1604	See
	Successive document: N/A	<a href="http://www.spieth-me.de/english/service-download/catalogue-instructions/">www.spieth-me.de/english/service-download/catalogue-instructions/</a>
	Created: 13 Apr 2018/Fd	For any questions, requests or suggestions, please contact
	Checked: 13 Apr 2018/Ax	<a href="mailto:info@spieth-me.de">info@spieth-me.de</a>