

Original version of the design guide



For	Components							
Spieth clamping set (precision clamping sets)	DSK 14.26	DSL 14.26	DSK 30.42	DSL 30.42	DSK 50.75	DSL 50.75	DSK 140.170	DSL 140.170
	DSK 15.28	DSL 15.28	DSK 30.47	DSL 30.47	DSK 50.80	DSL 50.80	DSK 150.180	DSL 150.180
	DSK 16.28	DSL 16.28	DSK 30.50	DSL 30.50	DSK 55.80	DSL 55.80	DSK 160.190	DSL 160.190
	DSK 16.32	DSL 16.32	DSK 30.55	DSL 30.55	DSK 55.85	DSL 55.85	DSK 170.200	DSL 170.200
	DSK 18.30	DSL 18.30	DSK 32.48	DSL 32.48	DSK 60.85	DSL 60.85	DSK 180.210	DSL 180.210
	DSK 18.35	DSL 18.35	DSK 32.52	DSL 32.52	DSK 60.90	DSL 60.90	DSK 190.230	DSL 190.230
	DSK 20.32	DSL 20.32	DSK 32.56	DSL 32.56	DSK 65.90	DSL 65.90	DSK 200.240	DSL 200.240
	DSK 20.37	DSL 20.37	DSK 35.52	DSL 35.52	DSK 65.95	DSL 65.95	DSK 210.250	DSL 210.250
Series	DSK 20.40	DSL 20.40	DSK 35.55	DSL 35.55	DSK 70.100	DSL 70.100	DSK 220.260	DSL 220.260
	DSK 22.35	DSL 22.35	DSK 35.60	DSL 35.60	DSK 75.105	DSL 75.105	DSK 230.270	DSL 230.270
DSK/DSL	DSK 22.38	DSL 22.38	DSK 40.56	DSL 40.56	DSK 80.110	DSL 80.110	DSK 240.280	DSL 240.280
	DSK 22.42	DSL 22.42	DSK 40.62	DSL 40.62	DSK 85.120	DSL 85.120	DSK 250.300	DSL 250.300
	DSK 25.37	DSL 25.37	DSK 40.65	DSL 40.65	DSK 90.120	DSL 90.120	DSK 260.310	DSL 260.310
	DSK 25.42	DSL 25.42	DSK 40.70	DSL 40.70	DSK 95.125	DSL 95.125	DSK 270.320	DSL 270.320
	DSK 25.45	DSL 25.45	DSK 45.68	DSL 45.68	DSK 100.130	DSL 100.130	DSK 280.330	DSL 280.330
	DSK 28.40	DSL 28.40	DSK 45.70	DSL 45.70	DSK 110.140	DSL 110.140	DSK 290.340	DSL 290.340
	DSK 28.45	DSL 28.45	DSK 45.75	DSL 45.75	DSK 120.150	DSL 120.150	DSK 300.350	DSL 300.350
	DSK 28.48	DSL 28.48	DSK 50.72	DSL 50.72	DSK 130.160	DSL 130.160		

The Design Guide is also available for download at www.spieth-me.de. In case of any questions, please contact Spieth-Maschinenelemente GmbH & Co. KG directly.

Legal:

SPIETH-MASCHINENELEMENTE GmbH & Co. KG, Alleenstraße 41, D - 73730 Esslingen
 Phone +49 711 930730 0 - Fax +49 711 930730 7
 E-Mail: info@spieth-me.de - Web: www.spieth-me.de
 KG: Esslingen HQ, Stuttgart county court, company register sect. A 210689
 PhG: Spieth-Beteiligungs-GmbH, Esslingen HQ, Stuttgart county court, company register sect. A 210636
 Managing director: Dipl.-Ing. Alexander Hund

©Spieth Proprietary notice ISO 16016	Previous document: ka-dskl-en1817	See
	Successive document: N/A	www.spieth-me.de/english/service-download/catalogue-instructions/
	Created: 28 Feb 2020/Fd	For any questions, requests or suggestions, please contact
	Checked: 28 Feb 2020/Ax	info@spieth-me.de

About the design guide for Spieth clamping sets

This design guide enables safe and efficient handling of Spieth clamping sets and provides valuable information on choice, dimensioning, and assembly of your friction-locked shaft-hub connection.

Notices

This design guide is based on the operating instructions whose recommendations and notices must be followed for dimensioning and design.

Please visit www.spieth-me.de for design guide and operating instructions.

The basic requirement for working safely is compliance with all safety notices. They can be identified by the following symbols:

Caution!

In addition to the notices in these instructions, local accident prevention guidelines and national health and safety regulations also apply.

Table of Contents

1	Description of Spieth Clamping Sets.....	3
1.1	Structure.....	3
1.2	Mode of action	3
2	Choice for Your Use Case.....	4
3	Design of Spieth Clamping sets	8
4	Dimensioning of Clamping set Connection	12
4.1	Transmittable forces and torques	12
4.2	Provided functional space and tolerances to be designed.....	12
5	How to Assemble Spieth Clamping sets	13
5.1	Precision-centering and aligning Spieth clamping sets	13
5.2	Interlocking Spieth clamping sets.....	13
6	Operating Spieth Clamping sets	17
7	Disassembling Spieth Clamping Sets	17
8	Disposing of Spieth Clamping Sets	18

1 Description of Spieth Clamping Sets

1.1 Structure

Spieth clamping sleeve
Spieth clamping screws

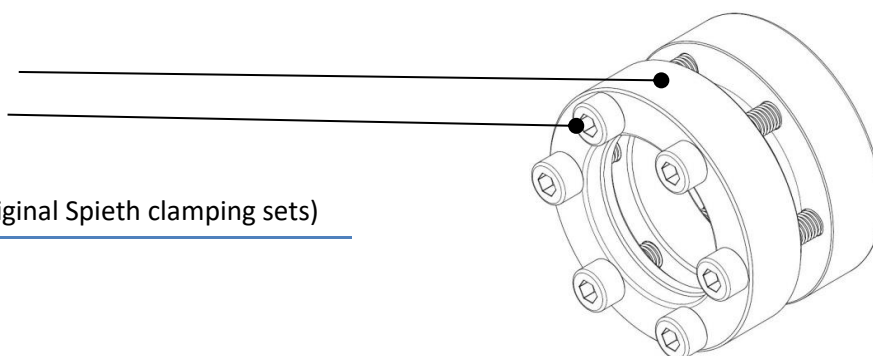

Identifying features (for original Spieth clamping sets)

Spieth logo

Name

Batch number

Pretensioning torque M_v of the clamping screws

Fig. 1: Schematic representation similar to Spieth DSK/DSL series clamping sets

Spieth DSK/DSL series clamping sets have been designed for use on shafts with h5-tolerance zone. The assembly consists of a clamping sleeve and clamping screws for integrated clamping initiation. In contrast to tapered clamping sets, the one-piece cylindrical clamping sleeve has no tolerance-heavy joints and can therefore achieve a higher degree of precision.

1.2 Mode of action

Spieth clamping sets are precision clamping sets. Due to their design, they provide a maximum of precision, combined with utmost resilience.

Spieth DSK/DSL series clamping sets have been designed as all-purpose precision clamping sets. This makes them an ideal solution for applications with a high level of replacements and adjustments.

Despite their compact design they can ensure continuous load transmission and rigid connections together with precise, centering and optimum concentricity for applications with high torques and axial forces.



Fig. 2: Illustration similar to Spieth DSK/DSL clamping sets

Spieth DSK/DSL series clamping sets are classified as friction-locked shaft-hub connections. Using clamping screws to initiate axial clamping achieves a uniform lateral contraction thanks to the base body's special geometry. The diaphragms are raised, widening the outer diameter and reducing the inner diameter, to create the required contact with shaft and hub for transmitting torques and axial forces. Thanks to this diaphragm principle, the connection is easy to assemble and quick to undo without the need for applying additional force.

©Spieth Proprietary notice ISO 16016	Previous document: ka-dskl-en1817	See
	Successive document: N/A	www.spieth-me.de/english/service-download/catalogue-instructions/
	Created: 28 Feb 2020/Fd	For any questions, requests or suggestions, please contact
	Checked: 28 Feb 2020/Ax	info@spieth-me.de

2 Choice for Your Use Case

The values specified in Table 1 apply to exclusively acting maximum transmittable torques and axial forces. The admissible torques and axial forces refer to the recommended tolerances of the connecting components.

They also apply to static and pulsating, alternating, or impact loads, provided the occurring peak forces stay below the specified maximum values. Alternating torsion stress or rotating bending stress is an exception for friction-locked connections because it may cause fretting corrosion. To avoid complicating the disassembly process, pay attention to the following details:

Admissible strain	For alternating torsion	$\tilde{T}_{zul} \leq 0,6 M_{max}$	[Nm]
	For rotating flex	$\tilde{M}_{b,zul} \leq 0,3 M_{max}$	[Nm]

The specified performance data are subject to the dispersion of the friction values of the different contact partners. The components are designed to be reusable, with frequent assembly and disassembly we recommend reducing the tightening torque. Please note that this can also reduce the transmissible torque.

Please note:

The details about the maximum load capacity of all Spieth products are based on the material's yield strength. The reason for this is that Spieth-Maschinenelemente GmbH & Co. KG only accepts elastic deformation of its products. Plastic deformation can complicate the disassembly process for precision clamping sets. With shaft-hub connections from other manufacturers, calculations are often based on tensile strength so a direct comparison of performance data is not possible.

Table 1: Application-relevant data of Spieth clamping sets

Name	DSK			DSL			DSK/DSL
	Order-No.	Transmittable forces		Order-No.	Transmittable forces		Precision
		Axial force $F_{ax,max}$ [N]	Torque T_{max} [Nm]		Axial force $F_{ax,max}$ [N]	Torque T_{max} [Nm]	Run-out accuracy [μ m] /IT4
14.26	K-11101401	5700	40	K-11201401	8600	60	8
15.28	K-11101501	5900	44	K-11201501	8800	66	8
16.28	K-11101601	5600	45	K-11201601	9100	73	8
16.32	K-11101602	12500	100	K-11201602	23400	187	8
18.30	K-11101801	5900	53	K-11201801	9700	87	8
18.35	K-11101802	12200	110	K-11201802	22800	205	8
20.32	K-11102001	6400	64	K-11202001	10000	100	8
20.37	K-11102002	13000	130	K-11202002	23000	230	8
20.40	K-11102003	18000	180	K-11202003	25000	250	8
22.35	K-11102201	6900	76	K-11202201	10000	110	8
22.38	K-11102202	14500	160	K-11202202	25000	275	8
22.42	K-11102203	30000	330	K-11202203	44100	485	8
25.37	K-11102501	7500	94	K-11202501	11200	140	8
25.42	K-11102502	17600	220	K-11202502	27800	348	8
25.45	K-11102503	31000	388	K-11202503	45300	566	8
28.40	K-11102801	8100	113	K-11202801	11400	160	8
28.45	K-11102802	20000	280	K-11202802	30000	420	8
28.48	K-11102803	32100	450	K-11202803	46600	653	8
30.42	K-11103001	8400	126	K-11203001	12000	180	8
30.47	K-11103002	21400	321	K-11203002	31300	470	8
30.50	K-11103003	34000	510	K-11203003	47000	705	8
30.55	K-11103004	39200	588	K-11203004	47800	717	8
32.48	K-11103201	22500	360	K-11203201	32500	520	8
32.52	K-11103202	36600	585	K-11203202	47500	760	8
32.56	K-11103203	39600	634	K-11203203	48100	770	8
35.52	K-11103501	22300	390	K-11203501	34300	600	8
35.55	K-11103502	38800	679	K-11203502	49800	871	8
35.60	K-11103503	53400	935	K-11203503	65700	1149	8

Name	DSK			DSL			DSK/DSL
	Order-No.	Transmittable forces		Order-No.	Transmittable forces		Precision
DSK/DSL		Axial force $F_{ax,max}$ [N]	Torque T_{max} [Nm]		DSK/DSL	Axial force $F_{ax,max}$ [N]	Torque T_{max} [Nm]
40.56	K-11104001	21500	430	K-11204001	34500	690	8
40.62	K-11104002	41800	835	K-11204002	52000	1040	8
40.65	K-11104003	55900	1118	K-11204003	68600	1372	8
40.70	K-11104004	63500	1270	K-11204004	71000	1420	8
45.68	K-11104501	43900	987	K-11204501	54800	1232	8
45.70	K-11104502	58100	1307	K-11204502	71400	1607	8
45.75	K-11104503	66000	1485	K-11204503	74100	1666	8
50.72	K-11105001	44600	1115	K-11205001	56500	1412	8
50.75	K-11105002	60000	1500	K-11205002	74000	1851	8
50.80	K-11105003	74000	1850	K-11205003	81700	2043	8
55.80	K-11105501	61600	1693	K-11205501	76500	2103	8
55.85	K-11105502	77100	2120	K-11205502	85200	2344	IT4
60.85	K-11106001	62800	1885	K-11206001	78600	2359	IT4
60.90	K-11106002	79000	2370	K-11206002	88300	2650	IT4
65.90	K-11106501	63800	2072	K-11206501	80500	2617	IT4
65.95	K-11106502	81500	2650	K-11206502	91400	2970	IT4
70.100	K-11107001	85400	2990	K-11207001	93900	3288	IT4
75.105	K-11107501	86700	3250	K-11207501	96100	3605	IT4
80.110	K-11108001	88000	3520	K-11208001	98000	3919	IT4
85.120	K-11108501	83800	3560	K-11208501	92900	3950	IT4
90.120	K-11109001	95600	4300	K-11209001	152200	6850	IT4
95.125	K-11109501	101100	4800	K-11209501	155600	7390	IT4
100.130	K-11110001	101000	5050	K-11210001	155600	7780	IT4
110.140	K-11111001	119500	6570	K-11211001	194400	10690	IT4
120.150	K-11112001	119500	7170	K-11212001	194500	11670	IT4
130.160	K-11113001	119400	7760	K-11213001	194500	12640	IT4
140.170	K-11114001	119400	8360	K-11214001	194400	13610	IT4
150.180	K-11115001	119500	8960	K-11215001	194400	14580	IT4
160.190	K-11116001	143400	11470	K-11216001	233400	18670	IT4
170.200	K-11117001	143300	12180	K-11217001	233300	19830	IT4

©Spieth Proprietary notice ISO 16016	Previous document: ka-dskl-en1817	See
	Successive document: N/A	www.spieth-me.de/english/service-download/catalogue-instructions/
	Created: 28 Feb 2020/Fd	For any questions, requests or suggestions, please contact
	Checked: 28 Feb 2020/Ax	info@spieth-me.de

Design Guide

DSK/DSL



Name	DSK			DSL			DSK/DSL
	Order-No.	Transmittable forces		Order-No.	Transmittable forces		Precision
Axial force $F_{ax,max}$ [N]		Torque T_{max} [Nm]	Axial force $F_{ax,max}$ [N]		Torque T_{max} [Nm]	Run-out accuracy [μ m] /IT4	
180.210	K-11118001	143300	12900	K-11218001	233300	21000	IT4
190.230	K-11119001	193700	18400	K-11219001	286300	27200	IT4
200.240	K-11120001	193000	19300	K-11220001	285400	28540	IT4
210.250	K-11121001	194300	20400	K-11221001	285300	29960	IT4
220.260	K-11122001	196400	21600	K-11222001	285400	31390	IT4
230.270	K-11123001	195700	22500	K-11223001	287000	33000	IT4
240.280	K-11124001	196700	23600	K-11224001	285400	34250	IT4
250.300	K-11125001	256000	32000	K-11225001	370400	46300	IT4
260.310	K-11126001	256200	33300	K-11226001	369200	48000	IT4
270.320	K-11127001	256300	34600	K-11227001	371900	50200	IT4
280.330	K-11128001	257100	36000	K-11228001	377100	52800	IT4
290.340	K-11129001	253800	36800	K-11229001	373800	54200	IT4
300.350	K-11130001	256700	38500	K-11230001	372000	55800	IT4

©Spieth Proprietary notice ISO 16016	Previous document: ka-dskl-en1817	See www.spieth-me.de/english/service-download/catalogue-instructions/
	Successive document: N/A	
	Created: 28 Feb 2020/Fd	For any questions, requests or suggestions, please contact info@spieth-me.de
	Checked: 28 Feb 2020/Ax	

3 Design of Spieth Clamping sets

Spieth DSK/DSL series clamping sets are made of steel with high material strength (approx. 650 N/mm²). The surface is bronzed with grinded functional surfaces.

The run-out accuracy of borehole / outside diameter is 0.008 mm and/or starting from $d_2 > 80$ mm, a concentricity accuracy as per IT4.

The outer diameter is machined as per ISO tolerance h5, the inner diameter is machined as per ISO tolerance H6.

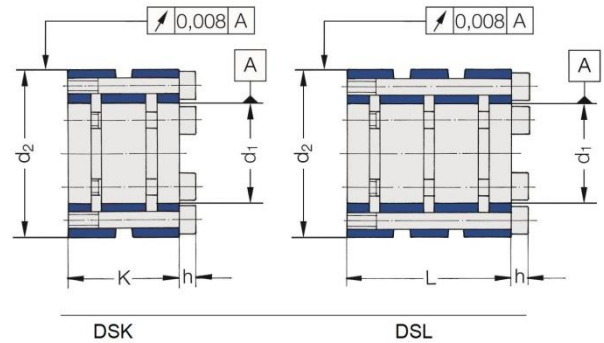

Fig. 3: Sectional view

Caution!

The clamping set is ductile in axial direction; therefore, handle it with care. Only actuate the clamping screws if the functional surfaces of the clamping set are fully covered by the connecting components.

Otherwise, damage such as plastic deformation may occur on the clamping set and render it unusable.

In such a case, Spieth-Maschinenelemente GmbH und Co. KG assumes no liability or warranty.

Caution!

Only use Spieth clamping sets with original Spieth clamping screws; otherwise, malfunctions with far-reaching consequences of loss may result.

In such a case, Spieth-Maschinenelemente GmbH und Co. KG assumes no liability or warranty.

©Spieth Proprietary notice ISO 16016	Previous document: ka-dskl-en1817	See www.spieth-me.de/english/service-download/catalogue-instructions/
	Successive document: N/A	
	Created: 28 Feb 2020/Fd	For any questions, requests or suggestions, please contact info@spieth-me.de
	Checked: 28 Feb 2020/Ax	

Table 2: Design data for dimensioning Spieth clamping sets

Name	Dimensions				Mass-related properties			
					DSK		DSL	
DSK/DSL	Length K/L [mm]	Length of- screw head h [mm]	Inner \varnothing d ₁ H6 [mm]	Outer \varnothing d ₂ h5 [mm]	Weight m [kg]	Mass moment of inertia J [Kg cm ²]	Weight m [kg]	Mass moment of inertia J [Kg cm ²]
14.26	21/31	3	14	26	0,042	0,045	0,056	0,059
15.28	21/31	3	15	28	0,048	0,059	0,062	0,078
16.28	21/31	3	16	28	0,046	0,058	0,062	0,077
16.32	31/41	4	16	32	0,104	0,161	0,120	0,179
18.30	21/31	3	18	30	0,05	0,074	0,066	0,099
18.35	31/41	4	18	35	0,12	0,227	0,136	0,25
20.32	21/31	3	20	32	0,054	0,093	0,072	0,124
20.37	31/41	4	20	37	0,13	0,278	0,144	0,307
20.40	36/52	5	20	40	0,182	0,434	0,234	0,547
22.35	21/31	3	22	35	0,062	0,131	0,084	0,173
22.38	31/41	4	22	38	0,128	0,302	0,146	0,334
22.42	36/52	5	22	42	0,192	0,519	0,248	0,653
25.37	21/31	3	25	37	0,062	0,155	0,084	0,206
25.42	31/41	4	25	42	0,15	0,439	0,172	0,484
25.45	36/52	5	25	45	0,206	0,666	0,270	0,839
28.40	21/31	3	28	40	0,068	0,203	0,092	0,269
28.45	31/41	4	28	45	0,162	0,562	0,186	0,619
28.48	36/52	5	28	48	0,224	0,84	0,290	1,06
30.42	21/31	3	30	42	0,072	0,24	0,096	0,318
30.47	31/41	4	30	47	0,168	0,655	0,194	0,722
30.50	36/52	5	30	50	0,236	0,973	0,308	1,23
30.55	41/62	6	30	55	0,34	1,59	0,468	2,13
32.48	31/41	4	32	48	0,168	0,69	0,190	0,764
32.52	36/52	5	32	52	0,25	1,12	0,318	1,41
32.56	41/62	6	32	56	0,342	1,69	0,466	2,26
35.52	31/41	4	35	52	0,194	0,936	0,218	1,03
35.55	36/52	5	35	55	0,264	1,36	0,346	1,72

Name	Dimensions				Mass-related properties			
					DSK		DSL	
DSK/DSL	Length K/L [mm]	Length of- screw head h [mm]	Inner Ø d ₁ H6 [mm]	Outer Ø d ₂ h5 [mm]	Weight m [kg]	Mass moment of inertia J [Kg cm ²]	Weight m [kg]	Mass moment of inertia J [Kg cm ²]
35.60	41/62	6	35	60	0,38	2,18	0,516	2,91
40.56	31/41	4	40	56	0,202	1,17	0,232	1,3
40.62	36/52	5	40	62	0,324	2,14	0,416	2,69
40.65	41/62	6	40	65	0,416	2,9	0,576	3,87
40.70	52/77	8	40	70	0,695	5,3	0,895	6,89
45.68	36/52	5	45	68	0,372	3,01	0,478	3,77
45.70	41/62	6	45	70	0,45	3,76	0,618	5,03
45.75	52/77	8	45	75	0,74	6,78	1,000	8,81
50.72	36/52	5	50	72	0,384	3,6	0,494	4,52
50.75	41/62	6	50	75	0,486	4,78	0,670	6,4
50.80	52/77	8	50	80	0,805	8,52	1,080	11,1
55.80	41/62	6	55	80	0,526	5,98	0,715	8
55.85	52/77	8	55	85	0,865	10,5	1,135	13,7
60.85	41/62	6	60	85	0,562	7,36	0,765	9,85
60.90	52/77	8	60	90	0,91	12,9	1,225	16,7
65.90	41/62	6	65	90	0,596	8,95	0,815	12
65.95	52/77	8	65	95	0,97	15,5	1,300	20,1
70.100	52/77	8	70	100	1,035	18,5	1,380	24
75.105	52/77	8	75	105	1,09	21,9	1,460	28,4
80.110	52/77	8	80	110	1,14	25,6	1,520	33,2
85.120	57/92	8	85	120	1,55	40,3	2,310	60,2
90.120	52/77	8	90	120	1,081	35,2	1,475	48,1
95.125	52/77	8	95	125	1,127	40,7	1,536	55,7
100.130	52/77	8	100	130	1,182	46,3	1,612	63,3
110.140	52/77	8	110	140	1,272	60,2	1,735	82,3
120.150	52/77	8	120	150	1,383	75,2	1,885	103
130.160	52/77	8	130	160	1,493	92,5	2,036	126

©Spieth Proprietary notice ISO 16016	Previous document: ka-dskl-en1817	See
	Successive document: N/A	www.spieth-me.de/english/service-download/catalogue-instructions/
	Created: 28 Feb 2020/Fd	For any questions, requests or suggestions, please contact
	Checked: 28 Feb 2020/Ax	info@spieth-me.de

Name	Dimensions				Mass-related properties			
					DSK		DSL	
DSK/DSL	Length K/L [mm]	Length of- screw head h [mm]	Inner Ø d ₁ H6 [mm]	Outer Ø d ₂ h5 [mm]	Weight m [kg]	Mass moment of inertia J [Kg cm ²]	Weight m [kg]	Mass moment of inertia J [Kg cm ²]
140.170	52/77	8	140	170	1,597	112	2,180	153
150.180	52/77	8	150	180	1,707	134	2,331	184
160.190	52/77	8	160	190	1,797	162	2,453	221
170.200	52/77	8	170	200	1,907	190	2,603	260
180.210	52/77	8	180	210	2,007	221	2,744	302
190.230	62/92	10	190	230	3,823	487	5,321	678
200.240	62/92	10	200	240	4,019	588	5,594	777
210.250	62/92	10	210	250	4,215	614	5,867	885
220.260	62/92	10	220	260	4,411	639	6,140	1000
230.270	62/92	10	230	270	4,607	812	6,413	1130
240.280	62/92	10	240	280	4,803	984	6,686	1270
250.300	72/102	10	250	300	7,528	1580	9,721	2050
260.310	72/102	10	260	310	7,818	1760	10,095	2280
270.320	72/102	10	270	320	8,107	1950	10,469	2520
280.330	72/102	10	280	330	8,397	2150	10,844	2780
290.340	72/102	10	290	340	8,687	2360	11,218	3060
300.350	72/102	10	300	350	8,977	2590	11,592	3360

©Spieth Proprietary notice ISO 16016	Previous document: ka-dskl-en1817	See www.spieth-me.de/english/service-download/catalogue-instructions/
	Successive document: N/A	
	Created: 28 Feb 2020/Fd	For any questions, requests or suggestions, please contact info@spieth-me.de
	Checked: 28 Feb 2020/Ax	

4 Dimensioning of Clamping set Connection

The overall rigidity of the connection between hub, clamping set, and shaft is influenced by a large number of parameters. They include not only characteristic material values but also the actual dimensions of the components used. Therefore, connection rigidity and resulting suitable revolution speed for clamping sets depend on the case at hand. In case of any questions, please contact Spieth-Maschinenelemente GmbH & Co. KG.

4.1 Transmittable forces and torques

The values specified in table 1 for transmissible torque M_{max} have been established from test series with connecting components made from steel C45 and manufactured in the prescribed surface quality. The values apply for a single/exclusively acting axial force at $F_{ax} = 0$ N and/or for a single acting torque at $M = 0$ Nm.

If both torque and axial force act on a clamping set at the same time, use Formula 1 to check whether transmissible torque M_{max} specified in Table 1 is greater than the calculated resultant torque M_r . Resultant torque M_r can be calculated from required torque M_{erf} and required axial force $F_{ax,erf}$.

$$M_{max} \geq M_r = \sqrt{F_{erf}^2 + \left(\frac{F_{ax,erf} \cdot d_1}{2000}\right)^2} \quad [Nm] \quad \text{(Formula 1)}$$

with	M_{max}	[Nm]	Maximum transmissible torque	Table value; Table 2
	M_{erf}	[Nm]	Required torque	
	M_r	[Nm]	Resultant torque	
	$F_{ax,erf}$	[N]	Required axial force	
	d_1	[mm]	Shaft diameter	

4.2 Provided functional space and tolerances to be designed

Ensure that the cylindrical borehole and outer surface of the clamping set are fully covered by the connecting components. Machine cylindrical shaft and borehole with a mean roughness depth of $R_z = 2.5 \dots 6.3 \mu\text{m}$.

4.2.1 Shaft

The rigidity of the shaft influences the required assembly pretension of the clamping set. All the details about pretensioning processes have been established using a solid shaft. If a hollow shaft is used, the resulting pretension may deviate.

For the shaft, a manufacturing tolerance of h5 (no more than h6 is admissible). For shafts with a tolerance of h6, the transmissible forces may decrease by approx. 10% in a worst case scenario.

In case of doubt, please contact Spieth-Maschinenelemente GmbH & Co. KG.

4.2.2 Hub

For hub boreholes, a manufacturing tolerance of H7 (or H6 for high run-out accuracy requirements) applies.

To ensure that hub strain remains within the elastic range, the following recommendations apply for minimum hub wall thickness:

Recommended minimum wall thickness	for steel C45:	$0.6 (d_2 - d_1)$	[mm]
	for AL alloy Minimum stability F38:	$1.0 (d_2 - d_1)$	[mm]
	for grey iron GG-25 void free cast	$1.0 (d_2 - d_1)$	[mm]

5 How to Assemble Spieth Clamping sets

5.1 Precision-centering and aligning Spieth clamping sets

Following joining and positioning, slightly tighten all the clamping screws to reduce the installation play. Tighten evenly, stepwise and crosswise to achieve precise centering. Therefore, this stage of play removal is of particular importance for the concentricity result. You need a commercial-grade screwdriver, a screw bit, or a spanner with hexagon socket.

5.2 Interlocking Spieth clamping sets

Continue to tighten the clamping screws to create the required seating stress between clamping set and hub / shaft. To do so, tighten the clamping screws evenly, stepwise and crosswise until the full pretensioning torque M_v (written on the component and/or as per Table 3).

As the power transmission of the clamping sets depends on the exerted clamping force, the clamping screws should be tightened using a torque wrench. During this process, the clamping set shrinks by a few tenths of a mm, which, despite a symmetrically acting operating force from the clamping screws, can result in a minor axial displacement of the clamped part in undefined direction.

Afterwards, check the tightening torque of the clamping screws all across.

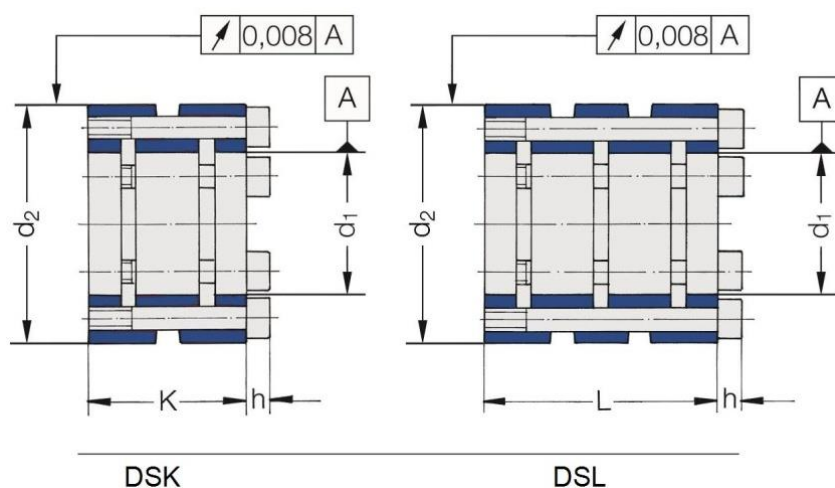

Fig. 4: Sectional view of Spieth DSK/DSL clamping sets

Table 3: Assembly-related data for tightening the clamping screws to lock the clamping set

Series designation		Pretensioning torque M _v			Tool	Clamping screws
DSK	DSL	Step 1 = 50% M _{v050} [Nm]	Step 2 = 75% M _{v075} [Nm]	Final torque = 100% M _{v100} [Nm]	ISK size [-]	Amount x thread [-] x [-]
DSK 14.26	DSL 14.26	0.25	1.5	2	2.5	6xM3
DSK 15.28	DSL 15.28	1	1.5	2	2.5	6xM3
DSK 16.28	DSL 16.28	1	1.5	2	2.5	6xM3
DSK 16.32	DSL 16.32	2.5	3.75	5	3	6xM4
DSK 18.30	DSL 18.30	1	1.5	2	2.5	6xM3
DSK 18.35	DSL 18.35	2.5	3.75	5	3	6xM4
DSK 20.32	DSL 20.32	1	1.5	2	2.5	6xM3
DSK 20.37	DSL 20.37	2.5	3.75	5	3	6xM4
DSK 20.40	DSL 20.40	3.5	5.25	7	4	6xM5
DSK 22.35	DSL 22.35	1	1.5	2	2.5	6xM3
DSK 22.38	DSL 22.38	2.5	3.75	5	3	6xM4
DSK 22.42	DSL 22.42	5	7.5	10	4	6xM5
DSK 25.37	DSL 25.37	1	1.5	2	2.5	6xM3
DSK 25.42	DSL 25.42	2.5	3.75	5	3	6xM4
DSK 25.45	DSL 25.45	5	7.5	10	4	6xM5
DSK 28.40	DSL 28.40	1	1.5	2	2.5	6xM3
DSK 28.45	DSL 28.45	2.5	3.75	5	3	6xM4
DSK 28.48	DSL 28.48	5	7.5	10	4	6xM5
DSK 30.42	DSL 30.42	1	1.5	2	2.5	6xM3
DSK 30.47	DSL 30.47	2.5	3.75	5	3	6xM4
DSK 30.50	DSL 30.50	5	7.5	10	4	6xM5
DSK 30.55	DSL 30.55	6.5	9.75	13	5	6xM6
DSK 32.48	DSL 32.48	2.5	3.75	5	3	6xM4
DSK 32.52	DSL 32.52	5	7.5	10	4	6xM5
DSK 32.56	DSL 32.56	6.5	9.75	13	5	6xM6
DSK 35.52	DSL 35.52	2.5	3.75	5	3	6xM4
DSK 35.55	DSL 35.55	5	7.5	10	4	6xM5
DSK 35.60	DSL 35.60	8.5	12.75	17	5	6xM6
DSK 40.56	DSL 40.56	2.5	3.75	5	3	6xM4
DSK 40.62	DSL 40.62	5	7.5	10	4	6xM5
DSK 40.65	DSL 40.65	8.5	12.75	17	5	6xM6
DSK 40.70	DSL 40.70	12.5	18.75	25	6	6xM8

Design Guide

DSK/DSL

Series designation		Pretensioning torque M_V			Tool	Clamping screws
DSK	DSL	Step 1 = 50% M_{V050} [Nm]	Step 2 = 75% M_{V075} [Nm]	Final torque = 100% M_{V100} [Nm]	ISK size [-]	Amount x thread [-] x [-]
DSK 45.68	DSL 45.68	5	7.5	10	4	6xM5
DSK 45.70	DSL 45.70	8.5	12.75	17	5	6xM6
DSK 45.75	DSL 45.75	12.5	18.75	25	6	6xM8
DSK 50.72	DSL 50.72	5	7.5	10	4	6xM5
DSK 50.75	DSL 50.75	8.5	12.75	17	5	6xM6
DSK 50.80	DSL 50.80	17,5	26,25	35	6	6xM8
DSK 55.80	DSL 55.80	8.5	12.75	17	5	6xM6
DSK 55.85	DSL 55.85	17,5	26,25	35	6	6xM8
DSK 60.85	DSL 60.85	8.5	12.75	17	5	6xM6
DSK 60.90	DSL 60.90	17,5	26,25	35	6	6xM8
DSK 65.90	DSL 65.90	8.5	12.75	17	5	6xM6
DSK 65.95	DSL 65.95	17,5	26,25	35	6	6xM8
DSK 70.100	DSL 70.100	17,5	26,25	35	6	6xM8
DSK 75.105	DSL 75.105	17,5	26,25	35	6	6xM8
DSK 80.110	DSL 80.110	17,5	26,25	35	6	6xM8
DSK 85.120	DSL 85.120	17,5	26,25	35	6	6xM8
DSK 90.120	DSL 90.120	17,5	26,25	35	6	7xM8
DSK 95.125	DSL 95.125	17,5	26,25	35	6	8xM8
DSK 100.130	DSL 100.130	17,5	26,25	35	6	8xM8
DSK 110.140	DSL 110.140	16	24	32	6	10xM8
DSK 120.150	DSL 120.150	16	24	32	6	10xM8
DSK 130.160	DSL 130.160	16	24	32	6	10xM8
DSK 140.170	DSL 140.170	16	24	32	6	10xM8
DSK 150.180	DSL 150.180	16	24	32	6	10xM8
DSK 160.190	DSL 160.190	16	24	32	6	12xM8
DSK 170.200	DSL 170.200	16	24	32	6	12xM8
DSK 180.210	DSL 180.210	16	24	32	6	12xM8
DSK 190.230	DSL 190.230	30	45	60	8	12xM10
DSK 200.240	DSL 200.240	30	45	60	8	12xM10
DSK 210.250	DSL 210.250	30	45	60	8	12xM10
DSK 220.260	DSL 220.260	30	45	60	8	12xM10
DSK 230.270	DSL 230.270	30	45	60	8	12xM10

©Spieth Proprietary notice ISO 16016	Previous document: ka-dskl-en1817	See www.spieth-me.de/english/service-download/catalogue-instructions/
	Successive document: N/A	
	Created: 28 Feb 2020/Fd	For any questions, requests or suggestions, please contact info@spieth-me.de
	Checked: 28 Feb 2020/Ax	

Design Guide

DSK/DSL

Series designation		Pretensioning torque M_V			Tool	Clamping screws
DSK	DSL	Step 1 = 50% M_{V050} [Nm]	Step 2 = 75% M_{V075} [Nm]	Final torque = 100% M_{V100} [Nm]	ISK size [-]	Amount x thread [-] x [-]
DSK 240.280	DSL 240.280	30	45	60	8	12xM10
DSK 250.300	DSL 250.300	30	45	60	8	15xM10
DSK 260.310	DSL 260.310	30	45	60	8	15xM10
DSK 270.320	DSL 270.320	30	45	60	8	15xM10
DSK 280.330	DSL 280.330	30	45	60	8	15xM10
DSK 290.340	DSL 290.340	30	45	60	8	15xM10
DSK 300.350	DSL 300.350	30	45	60	8	15xM10

©Spieth Proprietary notice ISO 16016	Previous document: ka-dskl-en1817	See www.spieth-me.de/english/service-download/catalogue-instructions/
	Successive document: N/A	
	Created: 28 Feb 2020/Fd	For any questions, requests or suggestions, please contact info@spieth-me.de
	Checked: 28 Feb 2020/Ax	

6 Operating Spieth Clamping sets

Spieth clamping sets are maintenance-free. During general maintenance work, we nevertheless recommend visually inspecting the clamping set and checking pretensioning torque M_V of the clamping screws. If used as intended, Spieth clamping sets and their high level of concentricity accuracy result in a friction-locked shaft-hub-connection for high torque values and axial forces.

7 Disassembling Spieth Clamping Sets

If handled correctly, Spieth clamping sets can be reused several times. Undo the clamping screws to return the cylindrical clamping set into its original shape.

In case you used a Spieth clamping set to friction-lock a shaft and a hub, due to the adjustments made you can only reconnect these two components after they have been disassembled.

Caution!

Undo all the clamping screws stepwise and crosswise to avoid overstraining the screws. Otherwise, the screws may fracture or the clamping set or adjoining components may be damaged.

To disassemble, proceed in reverse assembly order.

- 1. Remove the clamping force by undoing the clamping screws stepwise and crosswise.
- 2. After undoing the clamping screws, all parts of the connection regain their free movement.

Please note:

Following several assembly processes, the friction conditions on the clamping screws between upper and contact surfaces may change unfavourably. Tightening may result in stick-slip effects, resulting in erratic movements (cracking) of the clamping screws. In that case, first relubricate the screwhead support using normal machine oil without additives. If the stick-slip effects persist, replace the clamping screws by new original Spieth clamping screws.

Please note:

Following complete disassembly, slightly (manually) tighten the loosened clamping screws until they are flush. In any case, avoid tightening the clamping screws without fully covered contact surfaces of the clamping set.

To enable later reuse, clean, preserve, and store Spieth clamping sets correctly. If non-original Spieth spare parts are used, Spieth-Maschinenelemente GmbH & Co. KG assumes no liability or warranty.

©Spieth Proprietary notice ISO 16016	Previous document: ka-dskl-en1817	See
	Successive document: N/A	www.spieth-me.de/english/service-download/catalogue-instructions/
	Created: 28 Feb 2020/Fd	For any questions, requests or suggestions, please contact
	Checked: 28 Feb 2020/Ax	info@spieth-me.de

8 Disposing of Spieth Clamping Sets

You can easily reorder Spieth clamping sets by entering the component designation imprinted on the clamping set and the batch number.

Clamping sleeve and clamping screws of a Spieth clamping set are made of steel. At the end of their operating life, clean metal parts and dispose of them as scrap metal.

Please note:

For environmental reasons, please comply with applicable statutory regulations and guidelines when disposing of these products.