



# High Precision Stainless Steel Ball Bearings



HQW Precision GmbH  
The Barden Corporation (UK) Ltd

Partners in Precision







# Precision Bearings for Industrial Applications

Our range of high precision ball bearings offers the highest standards in quality and reliability, expertly manufactured in state-of-the-art, ISO 9001 certified production facilities based in Kürnach, Germany and Plymouth, UK.

Working together with The Barden Corporation (UK) as Partners in Precision, HQW Precision designs and manufactures precision bearings to ISO P2 (ABEC9) tolerance standards. Our engineering design service also provides for customised solutions which meet all our customer's performance requirements. In-house R&D activities, analysis and testing programs allow for full technical support across the development process. Depending on our customer's requirements, modifications, special design features, high performance materials and a wide selection of lubricants is available.

Our bearings represent the ideal combination of quality, precision and value for money. Suited to a wide range of applications across many industrial sectors, such as in the medical sector, automation and robotics, precision motors and drives and vacuum pump technology.

Our expert engineering team is on hand to help and advise on the best precision bearing solution for your application, please contact us for more information.



HQW Precision GmbH, Kürnach, Germany



The Barden Corporation (UK) Ltd, Plymouth, United Kingdom

## Contents

Materials for Rings and Balls .....	4
Limiting Speeds .....	4
Cages .....	5
Shields and Seals .....	6
Lubrication .....	7
Functional Test .....	7
Shims and Spring Washers .....	8
Shaft Retaining Rings .....	9
Bore Retaining Rings .....	9
Shaft and Housing Shoulders .....	10
Duplex Bearings .....	11
Designation System .....	12-13
Deep Groove Ball Bearings - Metric .....	14-16
Deep Groove Ball Bearings - Inch .....	17
Tolerance Tables .....	18-21
Product Range.....	22



# Materials for Rings and Balls

Our ball bearings are made from chrome steel or stainless steel. Typically the bearing rings and balls are of the same base material. Ceramic balls can be used in all versions if required (hybrid ball bearings).

The chrome steel used is high quality, heat treatable and maintains a high level of strength when hardened. Ball bearings made from this kind of steel have an excellent service life at working temperatures up to 120°C.

The stainless steels used are martensitic steels and can be used at working temperatures up to 150°C without noticeable hardness loss. Improvements in steel production and heat treatment allow the load ratings of the chrome steel and the stainless steels to be the same.

The specific grade of steel used may vary between bearing types, the possible grades of stainless and chrome steel are shown in the table below. If you require a specific grade of material please contact us.

Characteristics	Unit	Stainless Steel			SV30	Carbon Chrome Steel			Ceramic
		AISI440C	X65Cr13	9Cr18	X30CrMoN15-1	SAE52100	100Cr6	GCr15	Si <sub>3</sub> N <sub>4</sub>
Density	g/cm <sup>3</sup>	7.75			7.85	7.85			3.2
Hardness	HRC	>58			>58	>58			>75
E-modulus	GPa	200			218	201			320
Poissons Coefficient	-	0.28			0.3	0.29			0.26
Expansion Coefficient	X10 <sup>-6</sup> 1/°C	10.1			10.1	12.1			2.9
Top Temperature Limit	°C	150			180/450*	120			1000
Corrosion Resistance		Good			Very Good	Poor			Very Good
Electrical Conductivity		Conductor			Conductor	Conductor			Isolator
Magnetism		Magnetic			Magnetic	Magnetic			Not Magnetic

\* Temperature dependent on heat treatment process. Contact Engineering Dept. for further details.

Additional heat treatments are available on request for specific customer requirements. Contact Engineering Dept. for further details.







## Limiting Speeds

The maximum speed for a ball bearing in operation is limited by various mechanical and kinematic criteria. Narrow tolerances of bearings and surrounding parts, special measures regarding lubrication and type of lubricant as well as special retainer materials and designs generally have a beneficial effect on the speed limit.

The typical values for speed given in the tables only apply to specially set reference conditions. They therefore only give an indication of the relative speed suitability of the ball bearing. Ask our technical support for more information if operating conditions are different.

# Cages

The material and design of the cage can be selected to suit the application operating conditions. The following table shows the different types:

Reference	Image	Cage Type	Comments
J Jr Js Jrs		J - 2-part ribbon cage made of steel sheet. Jr - 2-part riveted cage made of steel sheet. Js - 2-part ribbon cage made of stainless steel. Jrs - 2-part riveted cage made of stainless steel.	Standard cage for deep groove ball bearings. Lightweight, low friction, long endurance.
Y Ys		Y - Crown cage made of steel. Ys - Crown cage made of stainless steel.	Often used for very small deep groove ball bearings. Lightweight, low friction, low and medium speeds.
TN9 TN9X		One-piece nylon snap cage made from polyamide, glass fiber reinforced version.	Low weight, higher speed, good running characteristics.
THA THB		Machined one-piece snap cage made of fiber-reinforced phenolic resin. A - outer ring guided B - inner ring guided	For high precision deep groove ball bearings. Very high speed, high stability, good emergency running capabilities. Oil impregnation available.
TxHA TxHB		Machined one-piece snap cage made of high performance, special plastic materials (PEEK, Torlon® and others). A - outer ring guided B - inner ring guided x - synonym for material	For deep groove ball bearings with very high speed. High stability, good emergency capabilities. Also suitable for high temperature applications (+260°C).
TA TB TxA TxB		Machined one-piece cage made of fiber-reinforced phenolic resin. A - outer ring guided B - inner ring guided	For high precision spindle bearings and very high speed, high stability, good emergency running capabilities, oil impregnation possible, also available made of high performance special plastic material (TxA, TxB, material: PEEK, Torlon®).
W		No cage, full ball complement.	Full complement deep groove ball bearing or angular contact ball bearing without cage, non-separable, shoulder relieved on outer or inner ring (angular contact ball bearing) or filling grooves for assembly of the balls (deep groove ball bearing, for low speed and high loads).

# Shields and Seals

The two basic types of bearing closures are shields and seals, both serve the same purposes with varying effectiveness. They exclude contamination, retain lubricants, and protect the bearing from internal damage during handling. Closures are attached to the outer ring. If they contact the inner ring they are seals. If they clear the inner ring they are shields.

Reference	Image	Design	Specificaton	Limitations
Open		No seals/shields.	Open.	Friction behaviour: +++ Easy to re-lube, no protection against contamination.
ZZs		Stainless steel shields.	Non-contact shields.	Friction behaviour: +++ Sealing effect: +
LLU		Rubber seals.	Contact seals made of Nitrile Butadiene Rubber (NBR).	Friction behaviour: + Sealing effect: +++
LLB		Rubber seals.	Non-contact seals made of Nitrile Butadiene Rubber (NBR).	Friction behaviour: +++ Sealing effect: ++
TISMZ		PTFE seals with metal shields.	Contact seals made of PTFE, additional metal shields on both sides.	Friction behaviour: ++ Sealing effect: +++ Good chemical durability.
FvLLU		Rubber seals.	Contact seals made of Fluoroelastomer (FKM/FPM).	Friction behaviour: + Sealing effect: +++ High temperature, good chemical durability.
FvLLB		Rubber seals.	Non-contact seals made of Fluoroelastomer (FKM/FPM).	Friction behaviour: +++ Sealing effect: ++ High temperature, good chemical durability.
TTS		PTFE seals.	Contact seals made of PTFE.	Friction behaviour: ++ Sealing effect: ++ Good chemical durability.

# Lubrication

Selecting the right lubricant type and method is just as important for the bearing function as selecting the bearing itself and designing the mating parts. The decision on a specific lubricant is made according to the operating conditions and the torque demands of the application.

## Lubricating Oils

Lubricating oils are mainly used where minimum torque is required.

Code	Brand Name	Manufacturer	Composition	Operating Temperature Range °C		Viscosity (mm <sup>2</sup> /s)		Specification
				Min	Max	40°C	100°C	
L95	Winsorlube L245x	Fuchs	Ester	-55	80	12.7	3.6	MIL-PRF-6085D
L10-20	Brayco Micronic 815Z	Castrol Inc.	PFPE	-72	204	141.0	44.3	
L10-6	Aeroshell Fluid 12	Shell	Synthetic Ester	-54	150	12.4	3.2	MIL-PRF-6085D
L10-17	Klubersynth MZ 4-17	Kluber	Ester/Hydrocarbon Oil	-54	150	18.0	4.0	

## Lubricating Greases

Code	Brand Name	Manufacturer	Composition	Operating Temperature Range °C		Viscosity (mm <sup>2</sup> /s)		Specification
				Min	Max	40°C	100°C	
L36-3	Braycote 601EF	Castrol	PFPE/PTFE	-80	204	141.0	44.3	
L42	Aeroshell Grease 7	Shell	Diester/Microgel	-73	149	10.3	3.1	MIL-PRF-23827C (Type II)
L21	Multemp SRL	Kyodo Yushi	Ester/Lithium Soap	-50	150	26.0	5.1	
LA09	Tribol GR 100-2 PD	Castrol	Mineral oil/Lithium	-35	140	95.0	9.0	
L4-1	Multemp SB-M	Kyodo Yushi	Synthetic Hydrocarbon/Diurea	-40	200	47.6	7.9	
LA71	Rivolta F.L.G.HF-2	Bremer & Leguil GmbH	Synthetic/Al Complex	-40	140	280.0	35.4	NSF-H1

dN definition = Bearing bore in mm x RPM

We would advise that lubricating greases with EP additives are not suitable for low-noise ball bearings.

The ball bearings can be lubricated with oils and greases other than those listed in the tables upon request and in quantities agreed upon. We have around 300 lubricants to choose from and can review any specific requirements not already in our portfolio.

## Functional Test

Functional tests on the assembled bearing include noise and torque tests. These tests ensure the consistency of the production run and guarantee compliance with customer requirements. The functional tests allow the parts to be constantly monitored for good roundness and surface finish.

### Noise Test

HQW high precision ball bearings are 100% noise-tested. We test the amplitude of the vibration generated by the ball bearings at set speeds and frequencies.

### Torque Test

Typically starting torque testing is performed on bearings which are intended for low torque applications. For these low torque applications we recommend that bearings are lubricated with an instrument oil with a viscosity of  $\leq 14\text{mm}^2/\text{s}$  at 40°C.

Torque-tested ball bearings are tested under cleanroom conditions in laminar flow cabinets. The starting torque is the torque required to start the rotation of one ring with the other ring stationary. The measurements made with the tester provide exact and reliable values, generally in accordance with MIL-STD-206A. The torque is tested on a vertical shaft with axial loading.

During the test, the inner ring is driven and the outer ring loaded with the standard load according to the bearing size. In this test the axial loading of the inner ring is 75g for ball bearings with an outside diameter up to 10mm. Ball bearings with a greater outside diameter are tested with a 400gm load.

Due to the lack of generally accepted standard torque, comparisons of bearings of the same type can only be made in identical measuring conditions on the same measuring equipment. Torque values are measured as standard without closures and bearings lubricated with instrument oil having a viscosity of  $\leq 14\text{mm}^2/\text{s}$  at 40°C. The torque value can be 10 to 40 times greater for ball bearings with grease lubrication.

# Shims and Spring Washers

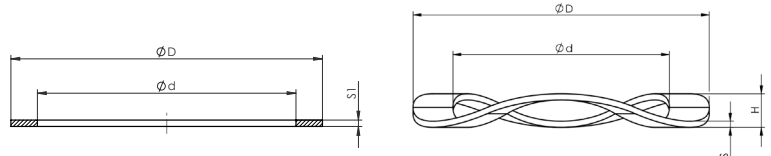

Dimensions [mm]			
Shims		Spring Washers	
d x D	s	d x D x H x s	Spring Constant [N/mm]
AS 1.55 x 2.50	0.10 0.12 0.15	-	-
-	-	WF 1.60 x 2.90 x 0.40 x 0.06	71.4
-	-	WF 1.90 x 2.80 x 0.50 x 0.08	62.5
AS 2.05 x 3.20	0.08 0.10	WF 2.15 x 3.10 x 0.50 x 0.08	47.1
AS 2.55 x 3.90	0.08 0.10	WF 2.70 x 3.80 x 0.50 x 0.08	42.7
AS 3.20 x 4.40	0.08 0.10 0.12	WF 3.20 x 4.30 x 0.50 x 0.10	50.0
AS 3.80 x 4.90	0.08 0.10 0.12	WF 3.70 x 4.80 x 0.55 x 0.10	28.6
AS 4.10 x 5.85	0.10 0.12 0.15	WF 4.20 x 5.75 x 0.65 x 0.12	41.5
AS 4.90 x 6.20	0.10 0.12 0.15	WF 4.80 x 6.10 x 0.60 x 0.12	30.6
AS 5.10 x 6.85	0.10 0.12 0.15	WF 5.20 x 6.75 x 0.65 x 0.12	28.6
AS 6.10 x 7.85	0.12 0.15 0.18	WF 6.20 x 7.75 x 0.70 x 0.15	48.7
AS 6.50 x 9.40	0.12 0.15 0.18	-	-
AS 7.10 x 8.80	0.12 0.15 0.18	WF 7.20 x 8.70 x 0.90 x 0.15	26.2
-	-	WF 7.20 x 12.00 x 1.40 x 0.12	16.4
AS 8.10 x 9.80	0.10 0.15 0.18 0.20	WF 8.20 x 9.70 x 0.85 x 0.18	38.0
AS 9.10 x 10.80	0.15 0.18 0.20	WF 9.20 x 10.70 x 1.15 x 0.18	23.3
AS 10.20 x 11.80	0.18 0.20 0.22	WF 10.20 x 11.70 x 1.05 x 0.20	23.9
-	-	WF 10.50 x 15.80 x 1.70 x 0.20	53.8
AS 11.20 x 12.80	0.18 0.20 0.22	WF 11.20 x 12.70 x 1.30 x 0.20	19.4
AS 12.30 x 13.80	0.20 0.22 0.25	WF 12.20 x 13.70 x 1.30 x 0.22	24.3
AS 13.30 x 14.80	0.20 0.22 0.25	WF 13.20 x 14.70 x 1.30 x 0.22	15.0
-	-	WF 13.20 x 18.80 x 1.60 x 0.20	32.3
AS 14.35 x 15.80	0.22 0.25 0.30	WF 14.20 x 15.65 x 1.55 x 0.25	16.2
AS 15.35 x 16.80	0.22 0.25 0.30	WF 15.20 x 16.65 x 1.55 x 0.25	13.8
AS 16.00 x 22.00	0.10 0.22 0.25	WF 15.80 x 21.80 x 1.60 x 0.20	28.5
AS 16.40 x 18.80	0.25 0.30 0.35	WF 16.20 x 18.55 x 2.15 x 0.30	27.1
-	-	WF 17.30 x 23.80 x 1.50 x 0.25	40.0
-	-	WF 19.30 x 25.80 x 1.90 x 0.35	70.8

Applicable For	
Shaft Types	Housing Types
681X	-
-	-
-	-
-	-
602X, 682X, 692X, R1-5	681X, 691, R0
623, 683, 693, R2-5, R2, R144, R2-6, R2A	-
-	682, 691X
604, 624, 634, 684, 694, R155	682X, 692
R3, R156, R166	R1-4, R144
625, 635, 685, 695	683, 692X
626, 686, 696	602X, 693, R1-5, R2-5, R155, R156
R168, R188, R4, R4A	-
607, 627, 687, 697	684
607, 627	R188, R1810, R2A
608, 688, 698, R1810	623
609, 629, 689, 699	685, 694
6800, 6900, R6	604
6000	625, 634
-	624, 686, 695
6801, 6901	687
R8	696
-	-
-	625, 634, 688, R4
6002, 6802, 6902, R10	689, 697
-	R6
-	607, 626, 635, 6800, 698, R4A
-	628, 609
-	629, 6000

Material 1.4310  
 Subject to alterations.  
 Please enquire about availability before selecting the shims and spring washers.



# Shaft Retaining Rings

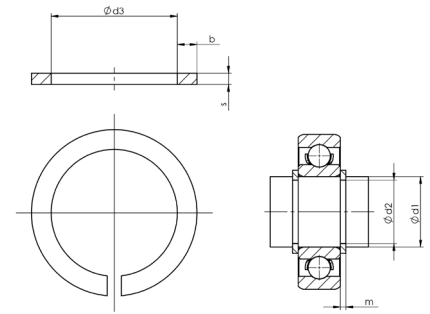

Type	Dimensions in mm					
	Shaft	Retaining Ring			Groove	
	d 1 diameter	d 3 max.	b $\pm 0.10$	s $\pm 0.02$	d 2 -0.05	m + 0.03
WSR 3	3	2.60	0.50	0.30	2.70	0.33
WSR 4	4	3.60	0.50	0.30	3.70	0.33
WSR 5	5	4.50	0.70	0.40	4.60	0.44
WSR 6	6	5.45	0.70	0.40	5.60	0.44
WSR 7	7	6.45	0.70	0.40	6.60	0.44
WSR 8	8	7.35	0.90	0.50	7.50	0.55
WSR 9	9	8.30	0.90	0.50	8.50	0.55
WSR 10	10	9.25	0.90	0.50	9.50	0.55

Material 1.4310 (AISI301).

# Bore Retaining Rings

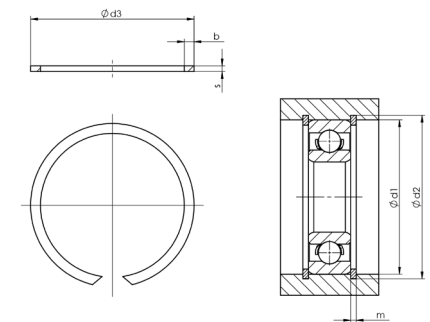

Type	Dimensions in mm					
	Bore	Retaining Ring			Groove	
	d 1 diameter	d 3 max.	b $\pm 0.10$	s $\pm 0.02$	d 2 -0.05	m + 0.03
BSR 4	4	4.40	0.50	0.30	4.30	0.33
BSR 5	5	5.45	0.50	0.30	5.30	0.33
BSR 6	6	6.45	0.50	0.30	6.30	0.33
BSR 7	7	7.50	0.50	0.30	7.30	0.33
BSR 8	8	8.60	0.70	0.40	8.40	0.44
BSR 9	9	9.60	0.70	0.40	9.40	0.44
BSR 10	10	10.65	0.70	0.40	10.40	0.44
BSR 11	11	11.65	0.70	0.40	11.40	0.44
BSR 12	12	12.75	0.90	0.50	12.50	0.55
BSR 13	13	13.75	0.90	0.50	13.50	0.55
BSR 14	14	14.80	0.90	0.50	14.50	0.55
BSR 15	15	15.80	0.90	0.50	15.50	0.55
BSR 16	16	16.85	0.90	0.50	16.50	0.55
BSR 17	17	17.85	0.90	0.50	17.50	0.55
BSR 19	19	20.00	1.10	0.60	19.60	0.66

Material 1.4310 (AISI301).



# Shaft and Housing Shoulders

The assembly conditions are very important for all bearings to function correctly. The shoulders for the inner and outer ring should allow the axial load to be transferred safely without allowing the rings to tilt against each other.

The following specifications should be taken into consideration:

- The radius on the shaft and housing must not be larger than the corner radius  $r_{min}$  of the ball bearing. An undercut is preferable here. The edge radii of the ball bearings are not suitable for locating the ball bearing in any way.
- The axial runout of the mating surfaces should not be greater than the maximum axial runout of the ball bearing used. The performance of the ball bearing could otherwise be influenced.

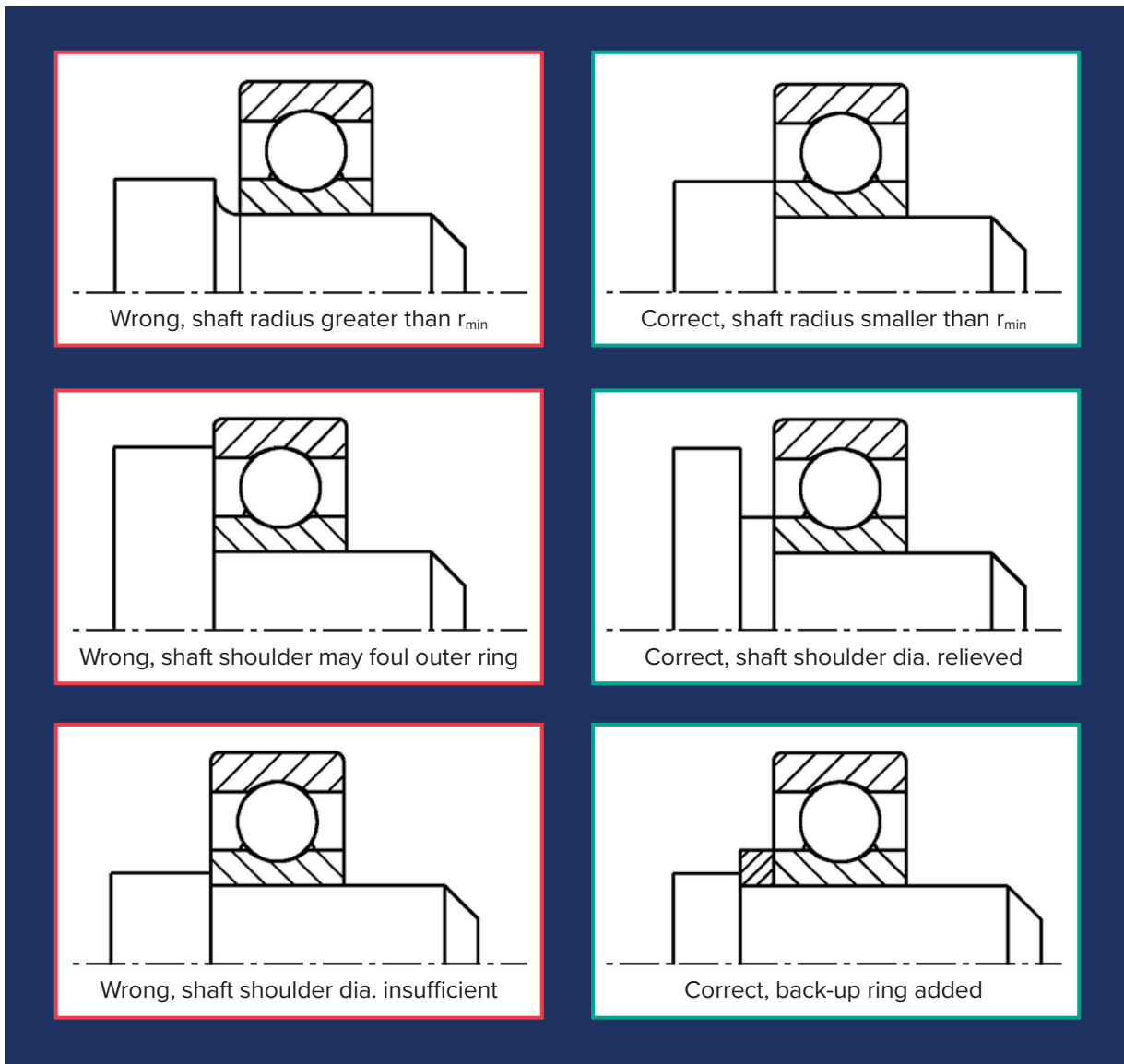

The principles applied in the above diagrams can equally be applied to the bearing housing.

# Duplex Bearings

Duplex bearings are matched bearings which, depending on the requirements, provide the following characteristics:

- Accurate bearing positioning in radial and axial directions, which can vary from defined clearance to controlled rigidity.
- Limitation of systems yield.
- Higher load capacity compared to single bearings.

The matching of the bearings is achieved by loading each single bearing with the desired preload and then grinding the inner or outer rings until the surfaces of both rings are flush with each other.

Two of the bearings treated in this manner are assembled according to the diagrams below and loaded axially until the ground faces meet, this repeats the preload previously set in manufacture. Depending on the matching used

either the inner rings or the outer rings or possibly both are preloaded against each other.

Unless specified otherwise ball bearings will be supplied with our standard preload level for that size, however this can be altered to suit operating conditions and requirements. The preload should not be set higher than necessary as it will unnecessarily increase the torque. This has a direct influence on the life of the ball bearing.

In order to achieve optimum fit, duplex bearings are always calibrated into two groups on the bore and outside diameter and supplied packaged with the same code. They should also, if possible, be fitted with calibrated shafts and housings.

The ball bearing fits should therefore be selected carefully as an interference fit on the inner or outer ring would change the preload.

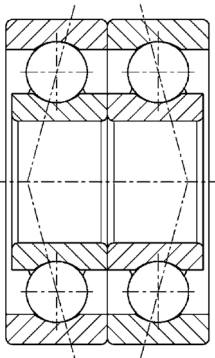

## Back-to-back (DB)

O arrangement

With the 'back-to-back' bearing pair the inner rings are clamped together. The contact angle between the outer ring raceway, ball and inner raceway diverge. This results in a maximum spread giving high rigidity. This is the reason why this type of duplex bearing is most commonly used.

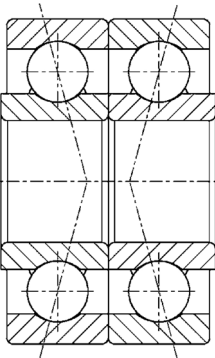

## Face-to-face (DF)

X arrangement

With the "face-to-face" bearing pair the outer rings are clamped together. The contact lines converge resulting in a smaller spread and more elasticity.

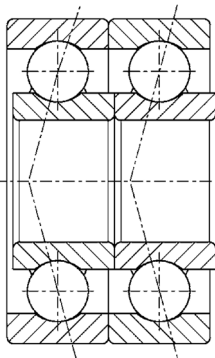

## Tandem (DT)

While duplex bearings mounted back-to-back or face-to-face are suitable to accommodate axial loading in both directions, a tandem mounted bearing pair can accept a very high axial load in one direction only. With this type of bearing pair, preloading and reduction of play can only be achieved by preloading against another bearing or bearing pair.



# HQW Designation System

Design		Ball Material		Ring Material		Layout		Basic Type		Internal Structure		Closure		Deviating Tolerances						
<b>LR</b>	Track roller	-	GCr15 (DIN 17320 1.3505; 100Cr6)	-	GCr15 (DIN 17320 1.3505; 100Cr6)	<b>F</b>	Flange	<b>692</b>	Metric	<b>d</b>	Deviating inner ring $\emptyset$	-	Open ball bearings	<b>d</b>	d0/-5 (inner $\emptyset$ )					
<b>QJ</b>	Four-point bearing	<b>S</b>	9Cr18 (SUS440C) X65Cr13 (1.4037)	<b>S</b>	9Cr18 (SUS440C) X65Cr13 (1.4037)	<b>B...</b>	Exended inner ring (e.g. B4,8)				<b>D</b>	Deviating outer ring $\emptyset$	<b>ZZ</b>	Shields	<b>D</b>	D0/-5 (outer $\emptyset$ )				
				<b>ZZs</b>	Stainless steel shields															
		<b>HYQ</b>	Si <sub>3</sub> N <sub>4</sub>	<b>SV</b>	X30Cr-MoN15-1								<b>W</b>	Deviating width	<b>LLU</b>	Standard contact seals	<b>W</b>	(width)	W0/-5	
		<b>HYZO</b>	ZrO <sub>2</sub>	<b>SX</b>	X40CrMo VN16-2											<b>LLH</b>				Light contact seals
				<b>CMQ</b>	Full ceramic Si <sub>3</sub> N <sub>4</sub>											<b>LLB</b>				Non-contact seals
		<b>CMZO</b>	Full ceramic ZrO <sub>2</sub>	<b>TTS</b>	Grinding seals made of PTFE															
		<sup>1</sup> For S/SV material: steel balls are made of X65Cr13										Additional closures available. See page 6 or on request								

Cage	Tolerance Class	Radial Clearance	Calibration of Diameter	Duplex Type/ Preload	Noise Test	Lubricant	Lubricant Quantity	Heat Treatment																			
J Two-part ribbon cage made of steel	- ABEC1 A3 ABEC3	# C0	X Sorting according to chart (please see below)	DB Back-to-back (O- Arrangement) <>	V2 100% checked	L ... Grease/ LA ... Oil	- 25-35% proportion of lubrication on existing free volume	S0 Tempered up to 150°C																			
Jr Two-part riveted cage made of steel	A5 ABEC5																										
Js Two-part ribbon cage made of stainless steel	A7 ABEC7 A9 ABEC9																										
Jrs Two-part riveted cage made of stainless steel	A3P ABEC3P																										
Y One-piece crown cage made of steel	A5P ABEC5P A7P ABEC7P A9P ABEC9P	C3 C3							<table border="1"> <tr> <td></td> <td></td> <td colspan="2">D</td> </tr> <tr> <td></td> <td></td> <td>0/-2.5</td> <td>-2.5/5</td> </tr> <tr> <td></td> <td>Code</td> <td>1</td> <td>2</td> </tr> <tr> <td rowspan="2">d</td> <td>0/-2.5</td> <td>1</td> <td>11 12</td> </tr> <tr> <td>-2.5/5</td> <td>2</td> <td>21 22</td> </tr> </table>			D				0/-2.5	-2.5/5		Code	1	2	d	0/-2.5	1	11 12	-2.5/5	2
		D																									
		0/-2.5	-2.5/5																								
	Code	1	2																								
d	0/-2.5	1	11 12																								
	-2.5/5	2	21 22																								
Ys One-piece crown cage made of stainless steel	C8/13 min/ max. value	Example: Code 11 (= bore Ø 0/-2µm, outer Ø 0/-2.5µm)	DT Tandem << or >>	CT ... Special treatment	5mg Absolute value of the amount of lubricant	S3 Tempered up to 300°C																					
W Full complement			U Universal << >>				S4 Tempered up to 350°C																				
THA Snap cage made of fiber-reinforced phenolic resin. Outer ring guided/inner ring guided (machined)			/ ... Preload in N																								
Additional cage types available. See page 5 or on request			Example: DB/5 (= paired bearing 'back-to-back' with 5N preload)					Additional lubricant quantities on request	S5 Tempered up to 450°C																		

# Deep Groove Ball Bearings (Metric)

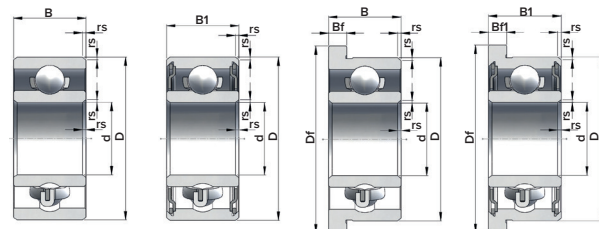

Basic Part Number	Dimensions							Load Rating		Limiting Speed		
	Bore Diameter d [mm]	Outside Diameter D [mm]	Width		Flange			Radius r <sub>min</sub> [mm]	Dynamic C [N]	Static C <sub>0</sub> [N]	Oil [min <sup>-1</sup> ]	Grease [min <sup>-1</sup> ]
			Open B [mm]	Shielded B1 [mm]	Ø Df [mm]	Bf [mm]	Bf <sub>1</sub> [mm]					
681	1	3	1	-	3.8	0.3	-	0.05	80	22	150000	130000
681X	1.5	4	1.2	2	5	0.4	0.6	0.05	160	44	120000	100000
691X	1.5	5	2	2.6	6.5	0.6	0.8	0.15	187	58	100000	85000
672	2	4	1.2	2	-	-	-	0.05	123	39	104000	91000
682	2	5	1.5	2.3	6.1	0.5	0.6	0.08	187	58	100000	85000
MR52	2	5	2	2.6	6.2	0.6	0.6	0.1	188	59	100000	85000
692 W2,3	2	6	2.3	2.3	7.5	0.6	0.8	0.15	275	89	90000	75000
692	2	6	2.3	3	7.5	0.6	0.8	0.15	275	89	90000	75000
MR62	2	6	2.5	2.5	7.2	0.6	0.6	0.15	275	89	90000	75000
MR72	2	7	2.5	3	8.2	0.6	0.6	0.15	310	109	75000	63000
602	2	7	2.8	3.5	8.5	0.7	0.9	0.15	310	109	75000	63000
68/2,35	2.35	5.5	2	2	7.5	0.6	0.8	0.15	275	89	90000	75000
682X	2.5	6	1.8	2.6	7.1	0.5	0.8	0.08	280	90	80000	71000
692X	2.5	7	2.5	3.5	8.5	0.7	0.9	0.15	425	149	75000	63000
MR82X	2.5	8	2.5	-	9.2	0.6	-	0.2	425	149	67000	60000
602X	2.5	8	2.8	4	9.5	0.7	0.9	0.15	425	149	71000	60000
MR63	3	6	2	2.5	7.2	0.6	0.6	0.1	208	73	80000	71000
673	3	6	2	2	7.2	0.6	0.6	0.08	255	80	78000	65000
683	3	7	2	3	8.1	0.5	0.8	0.1	310	111	75000	63000
MR83	3	8	2.5	3	9.2	0.6	-	0.15	450	154	67000	60000
693	3	8	3	4	9.5	0.7	0.9	0.15	560	179	67000	60000
MR93	3	9	2.5	4	10.2	0.6	0.8	0.2	570	188	67000	56000
603	3	9	3	5	10.5	0.7	1	0.15	570	187	67000	56000
623	3	10	4	4	11.5	1	1	0.15	630	218	60000	50000
633	3	13	5	5	15	1	1	0.2	1300	485	50000	42000
674	4	7	2	2	8.2	0.6	0.6	0.1	335	129	67000	60000
MR74	4	7	2	2.5	8.2	0.6	0.6	0.1	191	74	67000	60000
MR84	4	8	2	3	9.2	0.6	0.6	0.1	395	140	67000	56000
684	4	9	2.5	4	10.3	0.6	1	0.1	640	225	63000	53000
MR104	4	10	3	4	11.2	0.6	0.8	0.15	645	233	56000	48000
694	4	11	4	4	12.5	1	1	0.15	960	345	56000	48000
604	4	12	4	4	13.5	1	1	0.2	960	345	54000	46000
624	4	13	5	5	15	1	1	0.2	1300	485	48000	40000
634	4	16	5	5	18	1	1	0.3	1730	670	43000	36000
675	5	8	2	2	9.2	0.6	0.6	0.1	380	165	63000	53000
MR85	5	8	2	2.5	9.2	0.6	-	0.1	380	165	63000	53000
MR95	5	9	2.5	3	10.2	0.6	0.6	0.15	430	167	60000	50000
MR105	5	10	3	4	11.2	0.6	0.8	0.15	710	270	60000	50000
MR115	5	11	-	4	12.6	-	0.8	0.15	775	315	53000	45000



# Deep Groove Ball Bearings (Metric)

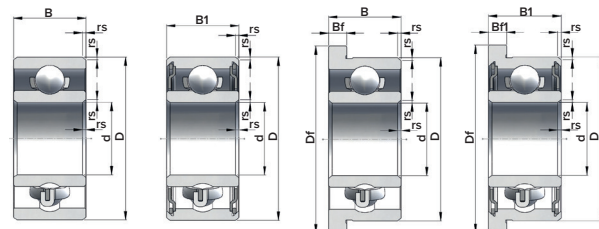

Basic Part Number	Dimensions								Load Rating		Limiting Speed	
	Bore Diameter d [mm]	Outside Diameter D [mm]	Width		Flange			Radius r <sub>min</sub> [mm]	Dynamic C [N]	Static C <sub>0</sub> [N]	Oil [min <sup>-1</sup> ]	Grease [min <sup>-1</sup> ]
			Open B [mm]	Shielded B1 [mm]	Ø Df [mm]	Bf [mm]	Bf <sub>1</sub> [mm]					
685	5	11	3	5	12.5	0.8	1	0.15	715	218	53000	45000
695	5	13	4	4	15	1	1	0.2	1080	430	50000	43000
605	5	14	5	5	16	1	1	0.2	1330	505	50000	40000
625	5	16	5	5	18	1	1	0.3	1730	670	43000	36000
635	5	19	6	6	22	1.5	1.5	0.3	2340	885	40000	32000
MR106	6	10	2.5	3	11.2	0.6	0.6	0.1	495	218	53000	45000
MR126	6	12	3	4	13.2	0.6	0.8	0.15	715	290	50000	43000
686	6	13	3.5	5	15	1	1.1	0.15	1080	440	50000	40000
696	6	15	5	5	17	1.2	1.2	0.2	1470	600	45000	40000
696 D16	6	16	5	5	-	-	-	0.2	1470	600	45000	40000
606	6	17	6	6	19	1.2	1.2	0.3	2260	835	45000	38000
626	6	19	6	6	22	1.5	1.5	0.3	2340	885	40000	32000
636	6	22	7	7	25	1.5	1.5	0.3	3300	1370	37000	31000
MR117	7	11	2.5	3	12.2	0.6	0.6	0.1	455	201	50000	43000
MR137	7	13	3	4	14.2	0.6	0.8	0.15	770	335	48000	40000
687	7	14	3.5	5	16	1	1.1	0.15	1170	510	45000	40000
697	7	17	5	5	19	1.2	1.2	0.3	1610	715	43000	36000
607	7	19	6	6	22	1.5	1.5	0.3	2340	885	43000	36000
627	7	22	7	7	25	1.5	1.5	0.3	3300	1370	36000	30000
637	7	26	9	9	29	2	2	0.3	4050	1620	34000	29000
MR128	8	12	2.5	3.5	13.2	0.6	0.8	0.1	540	270	48000	40000
MR148	8	14	3.5	4	15.6	0.8	0.8	0.15	870	420	45000	38000
688	8	16	4	5	18	1	1.1	0.2	1260	590	43000	36000
698	8	19	6	6	22	1.5	1.5	0.3	2240	910	43000	36000
608	8	22	7	7	25	1.5	1.5	0.3	3300	1370	40000	34000
628	8	24	8	8	26	2	2	0.3	3350	1430	34000	28000
638	8	28	9	9	30.25	2.25	2.25	0.3	4550	1970	33000	28000
679	9	14	3	4.5	15.5	0.8	0.8	0.1	915	465	42000	36000
689	9	17	4	5	19	1	1.1	0.2	1330	665	43000	36000
699	9	20	6	6	23	1.5	1.5	0.3	1720	840	40000	34000
609	9	24	7	7	27	1.5	1.5	0.3	3350	1430	38000	32000
629	9	26	8	8	28	2	2	0.6	4550	1970	34000	28000
639	9	30	10	10	32.5	2.5	2.5	0.6	5100	2390	31000	26000
6700	10	15	3	4	16.5	0.8	0.8	0.15	855	435	17000	15000
6800	10	19	5	5	21	1	1	0.3	1720	840	45000	38000
63800	10	19	7	7	21	1.5	1.5	0.3	1720	840	40800	34000
6900	10	22	6	6	25	1.5	1.5	0.3	2700	1270	38000	32000
6000	10	26	8	8	28	2	2	0.3	4550	1970	36000	30000
6200	10	30	9	9	32.25	2.25	2.25	0.6	5100	2390	30000	25000



# Deep Groove Ball Bearings (Metric)

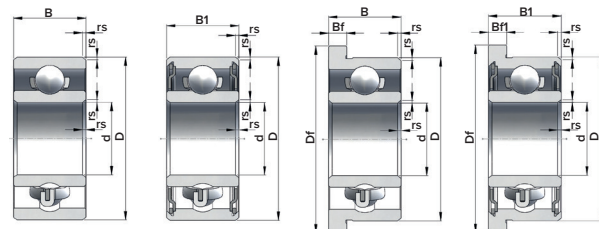

Basic Part Number	Dimensions							Load Rating		Limiting Speed		
	Bore Diameter d [mm]	Outside Diameter D [mm]	Width		Flange			Radius r <sub>min</sub> [mm]	Dynamic C [N]	Static C <sub>0</sub> [N]	Oil [min <sup>-1</sup> ]	Grease [min <sup>-1</sup> ]
			Open B [mm]	Shielded B1 [mm]	Ø Df [mm]	Bf [mm]	Bf <sub>1</sub> [mm]					
6300	10	35	11	11	37.75	2.75	2.75	0.6	8100	3450	27000	23000
6701	12	18	4	4	19.5	0.8	0.8	0.2	925	530	15000	13000
6801	12	21	5	5	23	1.1	1.1	0.3	1920	1040	40000	33000
63801	12	21	7	7	23	1.5	1.5	0.3	1920	1040	36000	30000
6901	12	24	6	6	26.5	1.5	1.5	0.3	2890	1460	36000	30000
6001	12	28	8	8	30	2	2	0.3	5100	2370	32000	28000
6201	12	32	10	10	34.5	2.5	2.5	0.6	6800	3050	28000	22000
6301	12	37	12	12	40	3	3	1	9700	4200	24000	20000
6702	15	21	4	4	22.5	0.8	0.8	0.2	935	585	13000	11000
6802	15	24	5	5	26	1.1	1.1	0.3	2080	1260	33000	28000
63802	15	24	7	7	26	1.5	1.5	0.3	2080	1260	32000	26000
6902	15	28	7	7	30.5	1.5	1.5	0.3	4350	2260	30000	26000
6002	15	32	9	9	34.25	2.25	2.25	0.3	5600	2840	28000	23000
6202	15	35	11	11	37.75	2.75	2.75	0.6	7650	3750	24000	20000
6302	15	42	13	13	45	3	3	1	11400	5450	20000	17000
6703	17	23	4	4	24.5	0.8	0.8	0.2	1000	680	11000	9500
6803	17	26	5	5	28	1.1	1.1	0.3	2230	1460	30000	26000
63803	17	26	7	7	28	1.5	1.5	0.3	2230	1460	27600	23000
6903	17	30	7	7	32.5	1.5	1.5	0.3	4600	2550	28000	24000
6003	17	35	10	10	37.5	2.5	2.5	0.3	6000	3250	24000	21000
6203	17	40	12	12	43	3	3	0.6	9550	4800	22000	17000
6303	17	47	14	14	50.5	3.5	3.5	1	13300	6650	19000	16000
6704	20	27	4	4	28.5	0.8	0.8	0.2	1040	780	10000	8500
6804	20	32	7	7	35	1.5	1.5	0.3	4000	2470	25000	21000
63804	20	32	10	10	35	2	2	0.3	4000	2470	25000	21000
6904	20	37	9	9	40	2	2	0.3	6400	3700	23000	19000
6004	20	42	12	12	45	3	3	0.6	9400	5000	20000	18000
6204	20	47	14	14	50.5	3.5	3.5	1	12800	6600	18000	15000
6304	20	52	15	15	55.75	3.75	3.75	1.1	15900	7900	17000	14000
6705	25	32	4	-	34	1	-	0.2	1390	1320	8000	7000
6805	25	37	7	7	40	1.5	1.5	0.3	4500	3150	21000	18000
63805	25	37	10	10	40	2	2	0.3	4500	3150	21000	18000
6905	25	42	9	9	45	2	2	0.3	7050	4450	19000	16000
6005	25	47	12	12	50	3	3	0.6	10100	5850	18000	15000
6205	25	52	15	15	55.75	3.75	3.75	1	14000	7850	15000	13000
6305	25	62	17	17	66	4	4	1.1	20600	11200	14000	11000

# Deep Groove Ball Bearings (Inch)

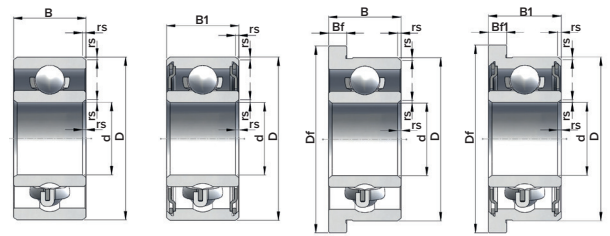

Basic Part Number	Dimensions								Load Rating		Limiting Speed	
	Bore Diameter d [mm]	Outside Diameter D [mm]	Width		Flange			Radius $r_{min}$ [mm]	Dynamic C [N]	Static $C_0$ [N]	Oil [min <sup>-1</sup> ]	Grease [min <sup>-1</sup> ]
			Open B [mm]	Shielded B1 [mm]	$\emptyset$ Df [mm]	Bf [mm]	Bf <sub>1</sub> [mm]					
R1-4	1.984	6.35	2.38	3.571	7.518	0.584	0.787	0.1	275	88	80000	67000
R133	2.38	4.762	1.588	2.38	5.944	0.457	0.787	0.1	188	59	95000	80000
R1-5	2.38	7.938	2.779	3.571	9.119	0.584	0.787	0.15	555	179	71000	60000
R144	3.175	6.350	2.380	2.779	7.518	0.584	0.787	0.1	310	108	80000	67000
R2-5	3.175	7.938	2.779	3.571	9.119	0.584	0.787	0.1	560	180	67000	60000
R2-6	3.175	9.525	2.779	3.571	10.719	0.584	0.787	0.15	640	227	63000	53000
R2	3.175	9.525	3.967	3.967	11.176	0.762	0.762	0.3	640	227	67000	56000
R2A	3.175	12.7	4.366	4.366	-	-	-	0.3	640	227	67000	56000
R155	3.967	7.938	2.779	3.175	9.119	0.584	0.914	0.1	395	140	63000	53000
R156	4.762	7.938	2.779	3.175	9.119	0.584	0.914	0.1	395	140	63000	53000
R166	4.762	9.525	3.175	3.175	10.719	0.584	0.787	0.1	710	270	60000	50000
FR3	4.762	12.7	4.978	-	14.351	1.067	-	0.3	1300	485	53000	43000
R3	4.762	12.7	3.967	4.978	14.351	-	1.067	0.3	1300	485	53000	43000
R3A	4.762	15.875	4.978	4.978	-	-	-	0.3	1460	595	45000	38000
R168	6.35	9.525	3.175	3.175	10.719	0.584	0.914	0.1	370	172	56000	48000
R188	6.35	12.7	3.175	4.762	13.894	0.584	1.143	0.15	1080	435	50000	40000
R4	6.35	15.875	4.978	4.978	17.526	1.067	1.067	0.3	1470	600	45000	38000
R4A	6.35	19.05	5.558	7.142	-	-	-	0.4	2340	885	43000	36000
R1810	7.938	12.7	3.967	3.967	13.894	0.787	0.787	0.15	540	270	48000	40000
R6	9.525	22.225	5.558	7.142	24.613	1.575	1.575	0.4	3330	1400	38000	32000
R8	12.7	28.575	6.35	7.938	31.12	1.575	1.575	0.4	4320	2250	32000	27000
R10	15.875	34.925	7.142	8.733	37.846	-	1.745	0.8	6000	3250	24000	21000
R12	19.05	41.275	7.938	11.113	-	-	-	0.8	9400	5000	20000	18000





# Tolerance Table - Inner Ring

Definition			Designation		A1		A3	
			ISO 492		Standard		Class 6	
			ANSI/ABMA		ABEC-1		ABEC-3	
			DIN 620		P0		P6	
			d [mm]		max	min	max	min
			>	≤				
Deviation of mean bore diameter in a single plane / Deviation of a single bore diameter	$\Delta_{dmp} / \Delta_{ds}$	-18	18 25	0 0	-8 -10	0 0	-7 -8	
Variation of bore diameter in a single plane	Diameter Series 7 / 8 / 9	$V_{dsp}$	-18 18	18 25	10 13		9 10	
	0 / 1	$V_{dsp}$	-18	18 25	8 10		7 8	
	2 / 3 / 4	$V_{dsp}$	-18	18 25	6 8		5 6	
Variation of mean bore diameter	$V_{dmp}$	-18	18 25	6 8		5 6		
Radial runout of inner ring of assembled bearing	$K_{ria}$	-2.5 2.5 10 18	2.5 10 18 25	10 10 10 13		5 6 7 8		
Perpendicularity of inner ring face with respect to the bore	$S_{di}$	-18	18 25					
Axial runout of inner ring of assembled bearing	$S_{ia}$	-2.5 2.5 10 18	2.5 10 18 25	15 20 20 25	not defined in ISO 492	10 15 20 20	not defined in ISO 492	
Deviation of a single inner ring width	$\Delta_{Bs}$ normal	-2.5 2.5 10 18	2.5 10 18 25	0 0 0 0	-40 -120 -120 -120	0 0 0 0	-40 -120 -120 -120	
Deviation of the total inner ring width for duplexed bearings	$\Delta_{Bs}$ modified a	-2.5	2.5 25	0	-250	0	-250	
Variation of inner ring width	$V_{Bs}$	-2.5 2.5 10	2.5 10 25	12 15 20		12 15 20		

A5		A7		A9		A3P		A5P		A7P		A9P	
Class 5		Class 4		Class 2		ABEC-3P		ABEC-5P		ABEC-7P		ABEC-9P	
ABEC-5		ABEC-7		ABEC-9									
P5		P4		P2									
max	min	max	min	max	min	max	min	max	min	max	min	max	min
0	-5	0	-4	0	-2.5	0	-5	0	-5	0	-5	0	-2.5
0	-6	0	-5	0	-2.5	0	-5	0	-5	0	-5	0	-2.5
5		4						2.5		2.5		1.5	
6		5						2.5		2.5		1.5	
4		3		2.5				2.5		2.5		1.5	
5		4		2.5				2.5		2.5		1.5	
4		3		2.5				2.5		2.5		1.5	
5		4		2.5				2.5		2.5		1.5	
3		2		1.5				2.5		2.5		1.5	
3		2.5		1.5				2.5		2.5		1.5	
4		2.5		1.5		5		4		2.5		1.5	
4		2.5		1.5		5		4		2.5		1.5	
4		2.5		1.5		5		4		2.5		1.5	
4		3		2.5		8		4		2.5		2.5	
7		3		1.5				8		2.5		1.5	
8		4		1.5				8		4		1.5	
7		3		1.5				8		2.5		1.5	
7		3		1.5				8		2.5		1.5	
7		3		1.5				8		2.5		1.5	
8		4		2.5				8		4		1.5	
0	-40	0	-40	0	-40	0	-120	0	-25	0	-25	0	-25
0	-40	0	-40	0	-120	0	-120	0	-25	0	-25	0	-25
0	-80	0	-80	0	-120	0	-120	0	-25	0	-25	0	-25
0	-120	0	-120	0	-120	0	-120	0	-25	0	-25	0	-25
0	-250	0	-250	0	-250								
0	-250	0	-250	0	-250								
5		2.5		1.5				5		2.5		1.5	
5		2.5		1.5				5		2.5		1.5	
5		2.5		1.5				5		2.5		1.5	



# Tolerance Table - Outer Ring

Definition			Designation		A1		A3	
			ISO 492		Standard		Class 6	
			ANSI/ABMA		ABEC-1		ABEC-3	
			DIN 620		P0		P6	
			D [mm]		max	min	max	min
			>	≤				
Deviation of mean outside diameter in a single plane / Deviation of a single outside diameter	$\Delta_{Dmp} / \Delta_{Ds}$	-	18	0	-8	0	-7	
		18	30	0	-9	0	-8	
		30	50	0	-11	0	-9	
		50	62	0	-13	0	-11	
Variation of outside diameter in a single plane	Diameter Series 7 / 8 / 9	$V_{Dsp}$	-	18	10		9	
			18	30	12		10	
			30	50	14		11	
			50	62	16		14	
	0 / 1	$V_{Dsp}$	-	18	8		7	
			18	30	9		8	
			30	50	11		9	
			50	62	13		11	
	2 / 3 / 4	$V_{Dsp}$	-	18	6		5	
			18	30	7		6	
			30	50	8		7	
			50	62	10		8	
Variation of mean outside diameter	$V_{Dmp}$	-	18	6		5		
		18	30	7		6		
		30	50	8		7		
		50	62	10		8		
Radial runout of outer ring of assembled bearing	$K_{ea}$	-	2.5	15		8		
		2.5	18	15		8		
		18	30	15		9		
		30	50	20		10		
		50	62	25		13		
Perpendicularity of outer ring outside surface with respect to the face	$S_D$	-	62					
Axial runout of outer ring of assembled bearing	$S_{ea}$	-	6	15		10		
		6	18	20		15		
		18	30	25	not defined in ISO 492	15	not defined in ISO 492	
		30	50	30		20		
		50	62	35		20		
Axial runout of outer ring flange back face of assembled bearing	$S_{ea1}$	-	18					
		18	50					
		50	62					
Deviation of a single outer ring width	$\Delta_{Cs}$ normal	-	18					
		18	50			Identical with $\Delta_{Cs}$		
		50	62					
Deviation of the total outer ring width for duplexed bearings	$\Delta_{Cs}$ modified b	-	62					
						Identical with $\Delta_{Cs}$		
Variation of outer ring width	$V_{Cs}$	-	18					
		18	30			Identical with $\Delta_{Bs}$ for inner ring of the same bearing		
		30	50					
		50	62					

A5		A7		A9		A3P		A5P		A7P		A9P	
Class 5		Class 4		Class 2		ABEC-3P		ABEC-5P		ABEC-7P		ABEC-9P	
ABEC-5		ABEC-7		ABEC-9									
P5		P4		P2									
max	min	max	min	max	min	max	min	max	min	max	min	max	min
0	-5	0	-4	0	-2.5	0	-8	0	-5	0	-5	0	-2.5
0	-6	0	-5	0	-4	0	-8	0	-5	0	-5	0	-4
0	-7	0	-6	0	-4	0	-8	0	-5	0	-5	0	-4
0	-9	0	-7	0	-4								
5		4						2.5		2.5		1.5	
6		5						2.5		2.5		2	
7		6						2.5		2.5		2	
9		7											
4		3		2.5				2.5		2.5		1.5	
5		4		4				2.5		2.5		2	
5		4		4				2.5		2.5		2	
7		5		4									
4		3		2.5				2.5		2.5		1.5	
5		4		4				2.5		2.5		2	
5		5		4				2.5		2.5		2	
7		5		4									
3		2		1.5				2.5		2.5		1.5	
3		2.5		2				2.5		2.5		2	
4		3		2				2.5		2.5		2	
5		3.5		2									
5		3		1.5		10		5		4		1.5	
5		3		1.5		10		5		4		2.5	
6		4		2.5		10		5		4		2.5	
7		5		2.5		10		5		5		2.5	
8		5		4									
8		4		1.5				8		4		1.5	
8		5		1.5				8		5		1.5	
8		5		1.5				8		5		1.5	
8		5		2.5				8		5		2.5	
8		5		2.5				8		5		2.5	
10		5		4									
11		7		3				8		8			
11		7		4				8		8			
14		7		6									
ΔBs for inner ring of the same bearing						0	-120	0	-25	0	-25	0	-25
ΔBs for inner ring of the same bearing													
5		2.5		1.5				5		2.5		1.5	
5		2.5		1.5				5		2.5		1.5	
5		2.5		1.5									
6		3		1.5									



# HQW Precision - Product Range

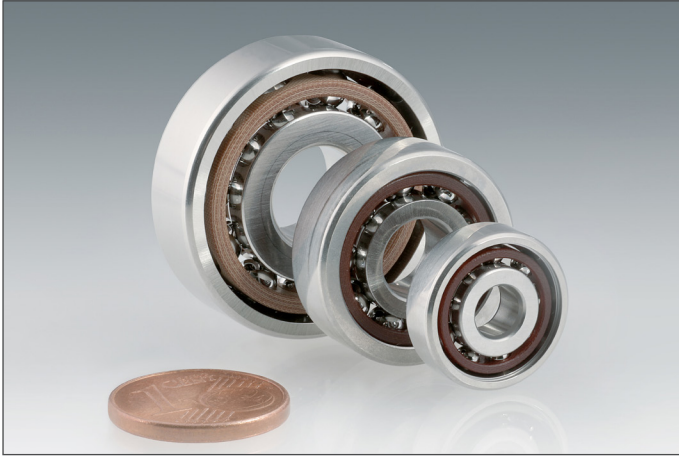

High Precision Spindle Bearings



Bearing Units



Thrust Rollers



Accessories and Precision Lock Nuts

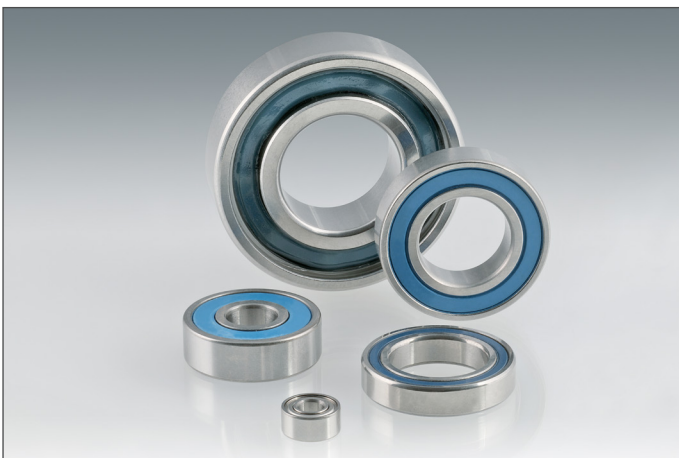

ActiveLube™ Solid Lubrication



Thin Section Ball Bearings



# Notes

---

A series of horizontal dotted lines for writing notes.





HQW Precision GmbH  
Wachtelberg 23  
97273 Kürnach  
Germany

Phone: +49 (0) 9367 98408-0  
Email: [info@hqw.gmbh](mailto:info@hqw.gmbh)  
Web: [www.hqw.gmbh](http://www.hqw.gmbh)

All technical data is considered correct at time of printing.  
No liability can be accepted for any technical alterations, errors or misprints.

This publication or parts thereof are protected by copyright  
and must not be reproduced without permission.

HQW-SSBB-09/2021-EN